



---

**MONITOR SPEAKER**

---

# MS150

---

**OPERATING MANUAL  
MODE D'EMPLOI  
BEDIENUNGSANLEITUNG**

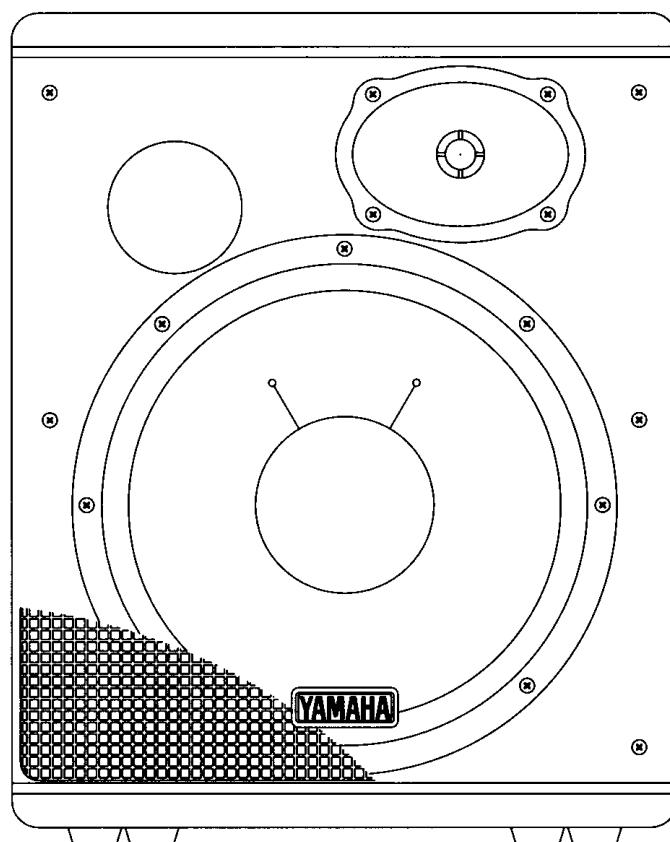

## **IMPORTANT NOTICE FOR THE UNITED KINGDOM**

### **Connecting the Plug and Cord**

**IMPORTANT:** The wires in this mains lead are coloured in accordance with the following code:

Blue	:	NEUTRAL
Brown	:	LIVE

As the colours of the wires in the mains lead of this apparatus may not correspond with the coloured markings identifying the terminals in your plug, proceed as follows:

The wire which is coloured **BLUE** must be connected to the terminal which is marked with the letter **N** or coloured **BLACK**.

The wire which is coloured **BROWN** must be connected to the terminal which is marked with the letter **L** or coloured **RED**.

**Making sure that neither core is connected to the earth terminal of the three pin plug.**

Thank you for purchasing a YAMAHA MS150 powered monitor speaker. The MS150 features a large 30 cm (12") bass unit and treble horn mounted in a bass reflex cabinet for efficient full-range reproduction of sound. The built-in amplifier provides a maximum output of up to 150W. Three independent protection circuits against short-circuits, overload and high frequency overload are provided.

The MS150 can accept up to three inputs simultaneously. One XLR-type input is balanced (+4 dB or -10 dB), and the other two (phone) are unbalanced. Inputs 1 and 2 can accept signals varying from mic level to line input level. Up to three MS150 units can be "cascaded", using the LINE OUT rear panel jack. A BYPASS switch allows cascaded sound to be sent through unchanged, or as affected by the two-way EQ and master volume controls on the first MS150 unit.

## CONTENTS

Precautions .....	1
Rear Panel .....	2
System Setup 1 .....	3
System Setup 2 .....	3
Specifications .....	4
Block & Level Diagram .....	4
Dimensions.....	5
Speaker protection circuits.....	5

## Precautions

---

1. Avoid excessive heat, humidity, dust and vibration.  
Keep the MS150 away from locations where it is likely to be exposed to high temperatures or humidity. Avoid excessively dusty locations, or locations subject to strong vibration, as these can cause mechanical damage.
2. Avoid physical shocks to the unit.  
Dropping the unit or otherwise subjecting it to mechanical shock can damage it. Handle it with care.
3. Do not open the unit or attempt repairs or modifications yourself.  
The MS150 contains no user-serviceable parts. All maintenance should be carried out by qualified Yamaha service personnel.
4. Turn off power before making or breaking connections.  
Always turn the power to the MS150 OFF before connecting or disconnecting cables. This will help to prevent damage to the unit itself, as well as to other connected equipment.
5. Handle cables carefully.  
Always plug and unplug any cables (including the AC power cable) by gripping the connector, not the cord itself.
6. Clean with a soft dry cloth.  
Do not use solvents (benzine, thinner, etc.) to clean the unit. Wipe it clean with a soft dry cloth.
7. If your unit is fitted with a grounding connection, use it.  
All units provided with a 3-wire power cable should be grounded, both for safety, and for optimum shielding against noise. If a 3-pin AC outlet is not available, or you suspect that the AC outlet is not grounded, a separate ground connection must be made from the chassis of the unit to an earth ground. Cold water pipes are generally a good ground, provided they are not insulated by PVC plastic, or fitted to a water meter. Avoid using hot water or gas pipes. If a convenient confirmed ground is not available, you can create one by driving a length of copper pipe to a depth of at least 1.5 meters (5 feet) into moist earth, or by using a chemical type grounding rod.
8. Always use the correct power source.  
Make sure that the power requirements specified on the rear panel match your local AC mains supply:  
US and Canadian models 120 VAC, 60 Hz  
General model 230 VAC, 50 Hz  
British model 240 VAC, 50 Hz

# Rear Panel

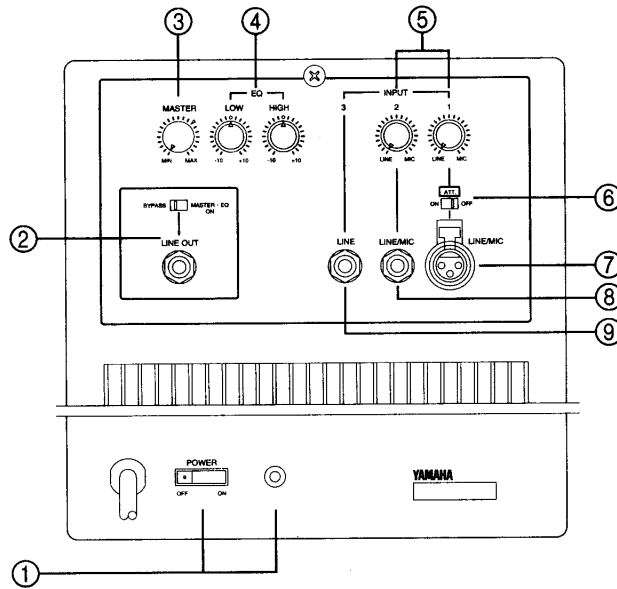

## ① POWER switch and indicator

When this switch is turned on, the indicator will light. Because of the protection circuitry, no sound will come from the speakers for 4-5 seconds after the power is turned on.

## ② LINE OUT jack and BYPASS switch

Use the LINE OUT jack when you want to "cascade" more than one MS150 speaker system. Use a mono phone plug to connect the MS150 speaker systems. Up to three MS150 speaker systems in total may be cascaded in this way.

The BYPASS switch is used in the following way.

When set to BYPASS, the signals input at jacks 1 through 3 will not be passed through the MS150's internal mixer EQ section, and will be output from the LINE OUT jack without equalization. The MASTER volume control will also be bypassed (turning the MASTER control will have no effect on the level output from the LINE OUT jack).

When set to MASTER • EQ ON, the MS150's internal mixer EQ controls and the MASTER volume control will affect the signal output from the LINE OUT jack.

## ③ MASTER volume control

This affects the volume from the MS150's speaker and the level from the LINE OUT jack (if the BYPASS switch is set to MASTER • EQ ON). Turn clockwise to increase the volume, counterclockwise to decrease it.

Turn this control to MIN when turning the MS150 power on or off.

## ④ EQ controls

These controls affect the sound output from the MS150's speaker, and from the LINE OUT jack (if the BYPASS switch is set to MASTER • EQ ON).

The LOW control provides 8 dB of 70 Hz cut (fully counterclockwise) or 8 dB of boost (fully clockwise).

The HIGH control provides 10 dB of 10 kHz cut (fully counterclockwise) or 10 dB of boost (fully clockwise).

When these controls are in the "click" center-detented position, these equalizer controls have no effect.

## ⑤ INPUT gain controls (1 and 2)

These two controls affect the level sent from inputs 1 and 2 to the pre-amplifier stage of the MS150's amplifier. When using a microphone (low-level), the appropriate control should be turned fully clockwise to the MIC

position (-50 dB). When using a line level source (an electronic instrument, a wireless microphone or a cassette recorder, etc.), turn the appropriate control counterclockwise to the LINE position (-10 dB).

If you are using a line level source, and the sound is distorted, turn the appropriate gain control fully counterclockwise. If the sound is still distorted, reduce the output volume of the line level source. If the sound is still distorted, you may need to connect the source to the XLR-type jack of input 1 and use the ATT switch ⑥.

## ⑥ ATT switch (attenuation)

This switch only affects the signal input at INPUT 1. If you are using a microphone (other than a wireless microphone), this switch should always be set OFF and gain control 1 set to MIC. For the majority of line sources, this switch should be set to OFF and gain control 1 set to LINE. Set the switch to ON and set gain control 1 to LINE when using "professional-level" (+4 dB) equipment. If in doubt, check the manual of the source equipment. If the specifications say something like: "Nominal output level: +4 dB", then you should set the MS150 ATT switch ON.

## ⑦ INPUT 1

This is an XLR-3-31 type balanced connector which can be used with balanced microphones and line level sources. Unbalanced sources can also be connected. Use gain control 1 and ATT (if necessary) to match the source input level so that the sound is not distorted. The pinouts for this XLR-type connector are:

- 1 Ground
- 2 Hot (+)
- 3 Cold (-)

## ⑧ INPUT 2

An unbalanced phone jack which can be used with microphones and line level sources. Use gain control 2 to match the source input level so that the sound is not distorted.

## ⑨ INPUT 3

An unbalanced phone jack which can be used with line level sources (-10 dB).

# System Setup 1

In this setup, two MS150s are used to amplify a microphone, electronic keyboard and CD player. The keyboard has two outputs (left and right) and so does the CD player. The left outputs from the keyboard and the CD player are fed to the left MS150 and the right outputs to the right MS150. The CD player is fed to the MS150s' Input 2s (the volume is controlled from the MS150s), and the keyboard is fed to the MS150s' Input 3s (the volume is controlled by the keyboard's volume control). The microphone can be fed to Input 1 of either of the two MS150s.

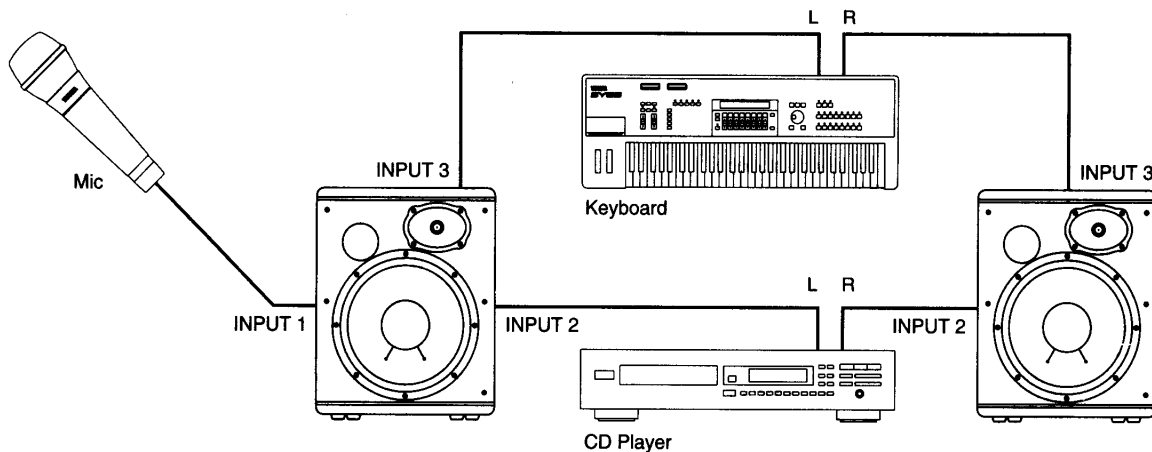

# System Setup 2

Here, a small mixer (the YAMAHA MV1000) is used to drive two "cascades" of three MS150 monitor speakers each (for clarity, only one cascade is shown here). The output from the MV1000 (here, either the left or the right output — the two setups are identical) is fed into one of the inputs (1 through 3) of the first MS150. The signal is then taken from the LINE OUT of the first MS150 and fed into the Input 3 of the second. It is then fed from the LINE OUT of the second MS150 into Input 3 of the third.

The BYPASS switch plays an important role here:

If this switch is set to BYPASS on the first two units, the EQ and master volume settings can be made independently for each speaker in the chain. This may be important if you want or need to tailor the equalization and volume for each speaker system on account of room acoustics, audience placement, etc.

If this switch is set to MASTER • EQ ON on the first two units, the master volume and EQ settings made on the first MS150 system will be reflected in the signal sent from the LINE OUT to the other MS150s. For example, if you want to increase the bass response on all of the MS150s simultaneously, all you need to do is to turn up the LOW control on the first MS150.

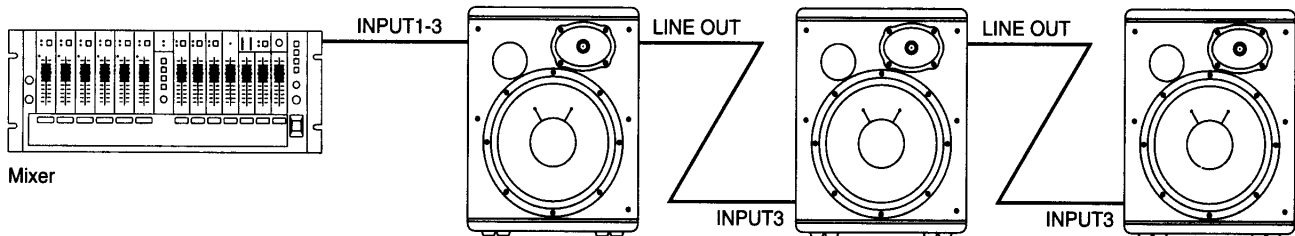

# Specifications

## ● General

### Type

Bass-reflex powered speaker

### Frequency range

50 Hz to 18 kHz (with HIGH and LOW set to center position)

### Maximum SPL

118 dB (1 m) on axis

### Dimensions (W × H × D)

373 × 470 × 301 mm (14-11/16" × 18-1/2" × 11-7/8")

### Weight

18 kg (48.2 lbs)

## ● Speaker section

### Components

30 cm (12 in) cone (JA32520A) × 1 — low frequency  
Horn (JA08570) × 1 — high frequency

### Sensitivity

97 dB (1 W, 1 m)

### Nominal impedance

6 Ω

## ● Amplifier section

### Inputs

- INPUT 1: (XLR-3-31 type, balanced)  
-50 dB to -10 dB / 7 kΩ with ATT off  
-36 dB to +4 dB / 10 kΩ with ATT on
- INPUT 2: (Phone jack, unbalanced)  
-50 dB to -10 dB / 10 kΩ
- INPUT 3: (Phone jack, unbalanced)  
-10 dB / 10 kΩ

### Outputs

- SP OUT: (RL = 6 Ω)  
150 W @ 1 kHz, THD = 1 %

## Output level and impedance

- LINE OUT: (Phone jack, unbalanced)  
-10 dB / 600 Ω (BYPASS)  
0 dB / 600 Ω (MASTER • EQ ON, MASTER at MAX, HIGH and LOW set to center position)  
frequency response  
30 Hz to 20 kHz (BYPASS)

## Hum and noise

- SP OUT: (RL = 6 Ω)  
≤ -66 dB (MASTER at MIN) Rs = 150 Ω, fc = 12.7 kHz, 6 dB/oct LPF
- LINE OUT (Phone jack, unbalanced):  
≤ -98 dB (ATT off, BYPASS, INPUT 1,2 LINE)  
Rs = 150 Ω, fc = 12.7 kHz, 6 dB/oct LPF

## ● Controls

- INPUT 1: Gain (MIC to LINE)
- INPUT 2: Gain (MIC to LINE)
- EQ (LOW): ±8 dB @ 70 Hz
- EQ (HIGH): ±10 dB @ 10 kHz
- MASTER volume
- INPUT1 ATT. switch (-14 dB)
- LINE OUT switch BYPASS / MASTER • EQ ON
- Power switch With LED indicator

## ● Power requirements

- US and Canadian models: 120 VAC, 60 Hz
- General model: 230 VAC, 50 Hz
- British model: 240 VAC, 50 Hz

## ● Power consumption

130 W

## ● Options

- Ceiling bracket (BCS 251)
- Wall bracket (BWS251-300,400)
- Baton bracket (BBS251)

Notes : 0 dB = 0.775 V

# Block & Level Diagram

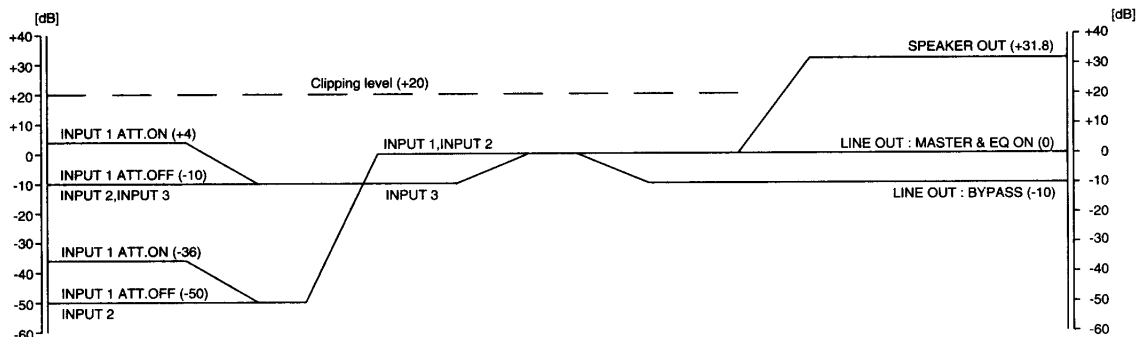
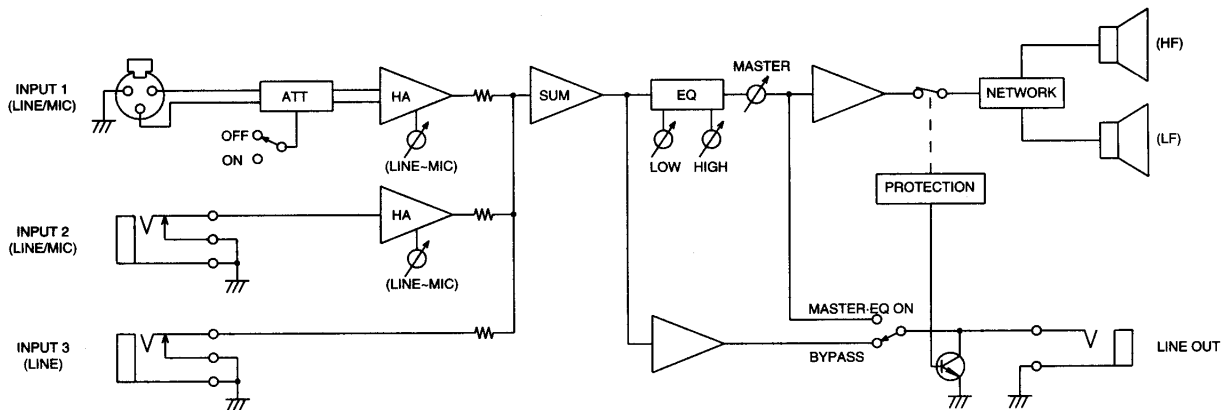

# Dimensions

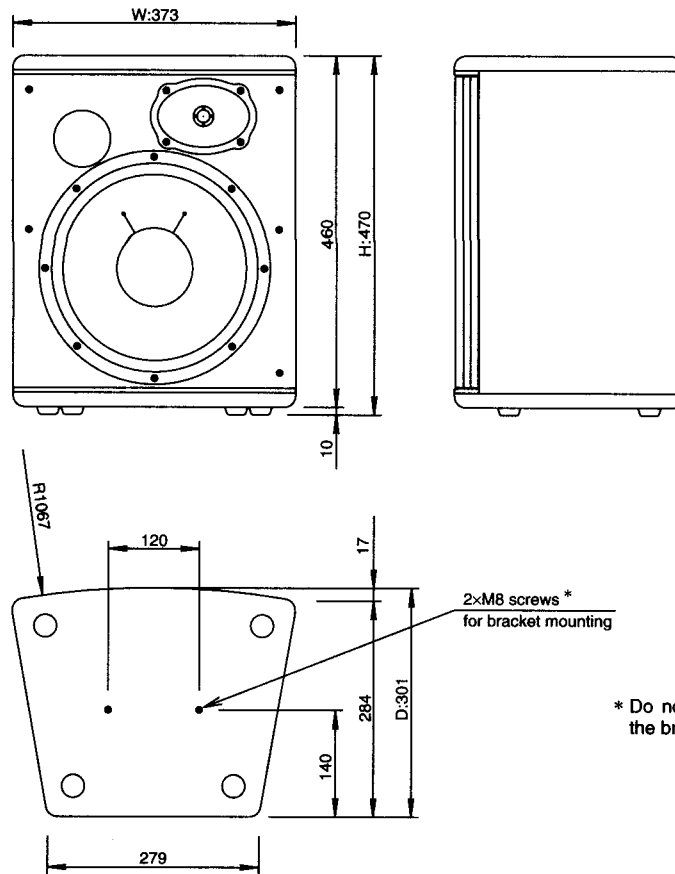

For European Model  
Purchaser/User Information specified in EN55103-1 and EN55103-2.  
Inrush Current: 10A  
Conformed Environment: E1, E2, E3 and E4

## Speaker protection circuits

The MS150 features three kinds of protection that protect the speaker from damage due to short circuits, overload or high-frequency overload. The circuits come into operation if:

1. If an abnormally high DC current is detected at the speaker (short-circuit).
2. If an abnormally high input is detected at one of the Input jacks.
3. If an abnormally high level of high-frequency sound is detected (the high frequencies only will be cut).

In the case of 1 and 2 above, normal sound will be automatically output again as soon as the conditions which caused the problem are cleared.

In the case of 3, it is necessary to turn off the unit, wait for 30 seconds for the unit to reset itself, and then turn on the unit again.

If any of these problems persist, even after you have cleared the obvious causes of the problem, contact your YAMAHA dealer.

