

# YAMAHA CDX-730 *RS* / CDX-530 *RS*

*Natural Sound Compact Disc Player*

*Lecteur de disque audionumérique de la série "Natural Sound"*

*Natural Sound CD-Spieler*

*Natural Sound Compact Disc-spelare*

*Lettore di Compact Disc a Suono Naturale*

*Tocadiscos de discos compactos de sonido natural*

COMPACT  
**disc**  
DIGITAL AUDIO

CENTER

## 改訂版

内容

本文中マーキング箇所  
訂正追加を致します。

OWNER'S MANUAL  
MODE D'EMPLOI  
BEDIENUNGSANLEITUNG  
BRUKSANVISNING  
MANUALE DELL'UTENTE  
MANUAL DE INSTRUCCIONES

**CAUTION**

As the laser beam used in this compact disc player is harmful to the eyes, do not attempt to disassemble the cabinet. Refer servicing to qualified personnel only.

**ACHTUNG**

Verwendung von Reglern, Einstellungen oder Eingriffe von anderer Natur als hierin angegeben kann die Aussetzung gefährlicher Strahlendosen nach sich ziehen.

**ADVARSEL**

Usynlig laserstråling ved åbning når sikkerafbryderen er ude af funktion. Undgå udsættelse for stråling.

- Dette apparat fungerer ved brug af laser-lys.
- Laserstrålingen er usynlig og farlig for øjnene.
- Apparatet må derfor kun åbnes af en kvalificeret tekniker.

**VAROITUS**

Suojakotelo ei saa avata. Laite sisältää laserdiodin, joka lähettää (näkyvätöntä) silmille vaarallista lasersäteilyä.

**OBSERVERA**

Utstrålingen från den laserkomponent som finns i denna laserprodukt överstiger den strålningsgräns som ställs för klass 1.

**OBSERVERA!**

Apparaten kopplas inte ur växelströmskällan (nätet) så länge som den är ansluten till vägguttaget, även om själva apparaten har stängts av.

**ADVERSEL**

Netspændingen til dette apparat er IKKE afbrudt, så længe netledningen sidder i en stikkontakt, som er tændt – også selvom der er slukket på apparatets afbryder.

- Dette apparat overholder det gældende EF-direktiv vedrørende radiostøj.
- Cet appareil est conforme aux prescriptions de la directive communautaire 87/308/CEE.
- Diese Geräte entsprechen der EG-Richtlinie 82/499/EWG und/oder 87/308/EWG.
- This product complies with the radio frequency interference requirements of the Council Directive 82/499/EEC and/or 87/308/EEC.
- Questo apparecchio è conforme al D.M.13 aprile 1989 (Direttiva CEE/87/308) sulla soppressione dei radiodisturbi.
- Este producto está de acuerdo con el radio de interferencia frecuente requisitos de el Concilio Directivo 87/308 EEC.

1

CDX-730

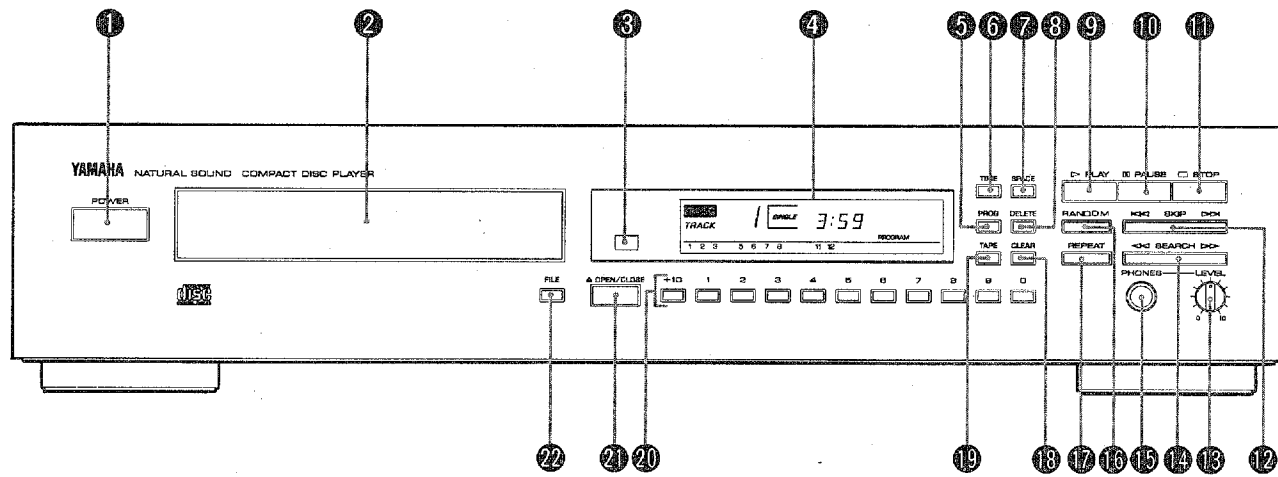

4 Display panel  
 Panneau d'affichage  
 Anzeigefeld

Displaypanel  
 Pannello display  
 Pantalla de indicadores

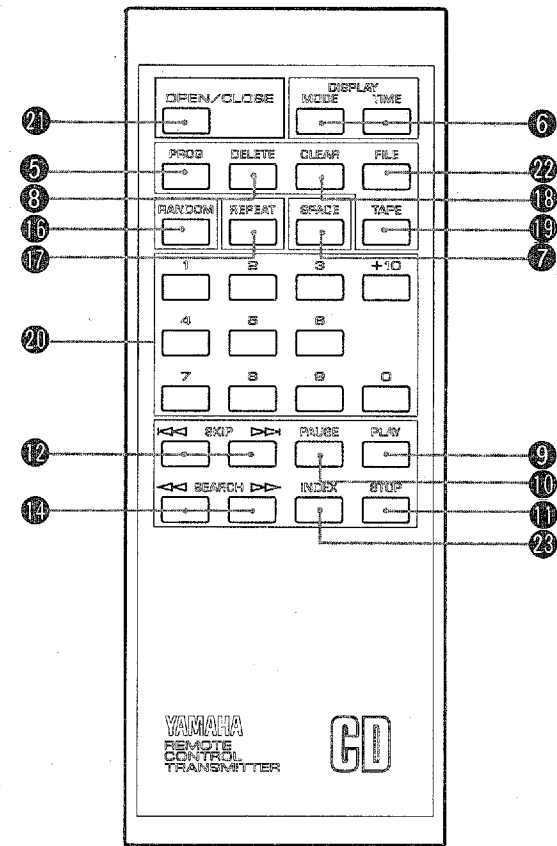
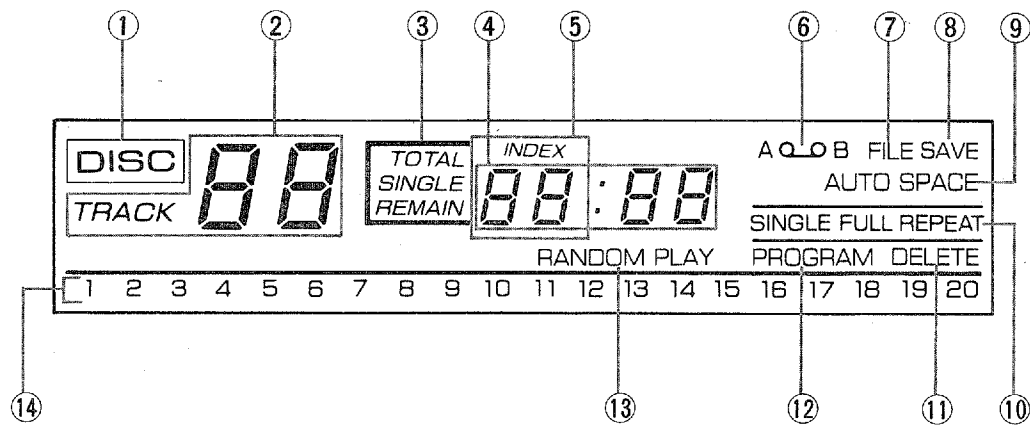

CDX-530

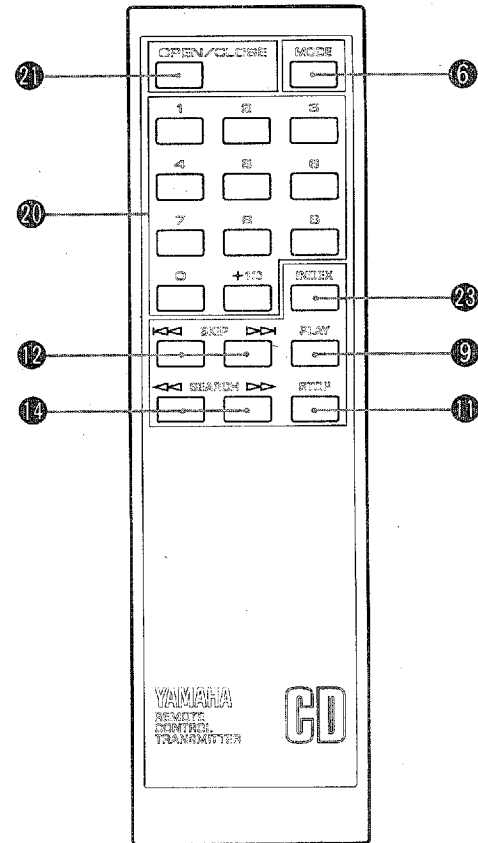
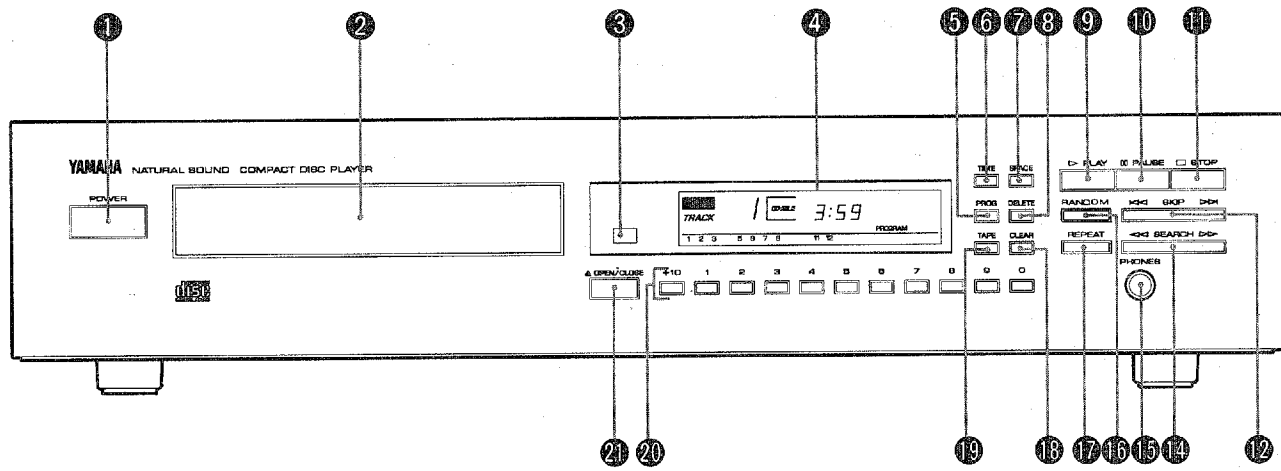

④ Display panel  
 Panneau d'affichage  
 Anzeigefeld

Displaypanel  
 Pannelo display  
 Pantalla de indicadores

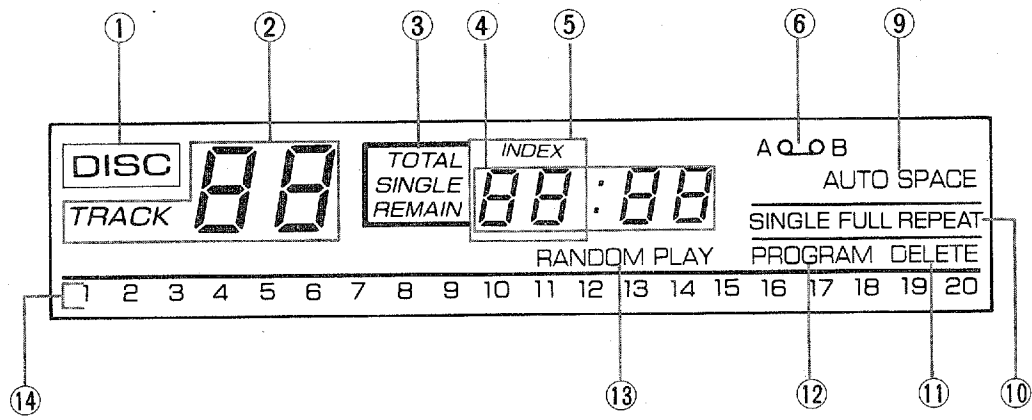

CONNECTIONS  
CONNEXIONS  
ANSCHLÜSSE  
ANSLUTNINGAR  
COLLEGAMENTI  
CONEXIONES

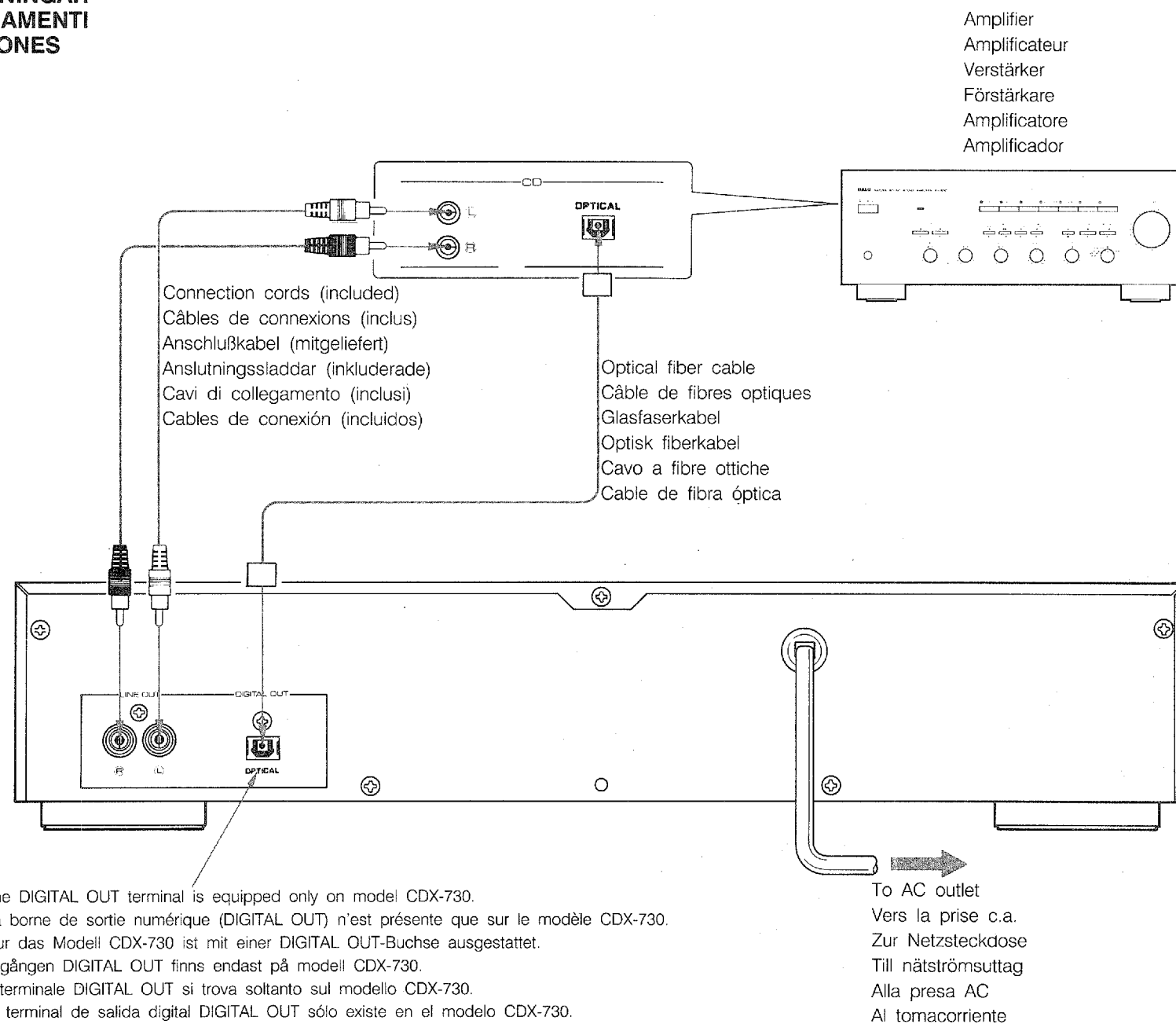

The DIGITAL OUT terminal is equipped only on model CDX-730.  
La borne de sortie numérique (DIGITAL OUT) n'est présente que sur le modèle CDX-730.  
Nur das Modell CDX-730 ist mit einer DIGITAL OUT-Buchse ausgestattet.  
Utgången DIGITAL OUT finns endast på modell CDX-730.  
Il terminale DIGITAL OUT si trova soltanto sul modello CDX-730.  
El terminal de salida digital DIGITAL OUT sólo existe en el modelo CDX-730.

**CAUTION: READ THIS BEFORE OPERATING YOUR UNIT.**

1. This unit is a sophisticated compact disc player. To ensure proper operation for the best possible performance, please read this manual carefully.
2. Choose the installation location of your unit carefully. Avoid placing it in direct sunlight or close to a source of heat. Also avoid locations subject to vibration and excessive dust, heat, cold or moisture. Keep it away from such sources of hum as transformers or motors.
3. Do not place this unit on top of another component, and do not place a television set or color monitor TV on top of this unit.
4. Do not open the cabinet of this unit, because to do so might result in damage to the unit, or injury by electric shock. If any foreign object or substance enters the unit, contact your dealer for assistance.
5. To prevent damage by lightning, disconnect the power cord from the household AC outlet during an electrical storm.
6. When disconnecting the power cord from the household AC outlet, grasp the plug; do not pull the cord.
7. Do not apply excessive force when using switches and controls.
8. When moving the unit, be sure to first disconnect the power cord from the household AC outlet, and disconnect cords connected to other equipment.
9. Do not attempt to clean the unit with chemical solvent as this might damage the finish. Use a clean, dry cloth.
10. Be sure to read the "Troubleshooting" section for advice on common operating errors before concluding that your unit is faulty.
11. Keep this manual in a safe place for future reference.
12. Voltage selector (General model only)  
The voltage selector (on the rear panel of this unit) must be correctly set to the voltage used locally before making any connection to the AC power supply.

**CAUTION (FOR CANADA MODEL):**  
TO PREVENT ELECTRIC SHOCK DO NOT USE THIS (POLARIZED) PLUG WITH AN EXTENSION CORD, RECEPTACLE OR OTHER OUTLET UNLESS THE BLADES CAN BE FULLY INSERTED TO PREVENT BLADE EXPOSURE.

**FOR CANADIAN CUSTOMER**  
THIS DIGITAL APPARATUS DOES NOT EXCEED THE "CLASS B" LIMITS FOR RADIO NOISE EMISSIONS FROM DIGITAL APPARATUS SET OUT IN THE RADIO INTERFERENCE REGULATION OF THE CANADIAN DEPARTMENT OF COMMUNICATION.

**WARNING**

To reduce the risk of fire or electric shock, do not expose this appliance to rain or moisture.

To avoid electrical shock, do not open the cabinet. Refer servicing to qualified personnel only.

**DANGER**  
Invisible laser radiation when open and interlock failed or defeated.  
Avoid direct exposure to beam.

**CAUTION**  
Use of controls or adjustments or performance of procedures other than those specified herein may result in hazardous radiation exposure.

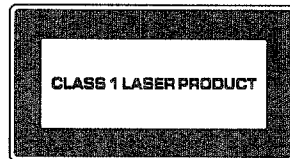

This compact disc player is classified as a CLASS 1 LASER product.  
The CLASS 1 LASER PRODUCT label is located on the rear exterior.

Laser component in this product is capable of emitting radiation exceeding the limit for Class 1.

## CAUTION

This Owner's Manual covers two models, the CDX-730 and the CDX-530. Before reading this Owner's Manual, therefore, the user should note the differences, described below, between the two models.

★	CDX-730	CDX-530
<b>SAVE indicator (on the front panel)</b>	Provided	Not Provided
<b>PHONES LEVEL volume control (on the front panel)</b>	Provided	Not Provided
<b>FILE button and indicator (on the front panel)</b>	Provided	Not provided
<b>DIGITAL OUT terminal (on the rear panel)</b>	Provided	Not provided

- The above specifications are slightly changed. Please refer to page 23.

The ★ symbol is used in this manual to designate information that is applicable to model CDX-730. Owners of model CDX-530 should therefore note that information so designated is not applicable to their unit.

## NOTES ABOUT HANDLING COMPACT DISCS

- This compact-disc player is designed only for reproduction of compact discs bearing the  mark. Never attempt to load any other type of disc into the unit. The unit will also play 3-inch (8-cm) compact discs.
- To remove a disc from its storage case, open the case and then press down at the center; with a finger through the center hole and the outer edges held as shown in the illustration, lift the disc out carefully.

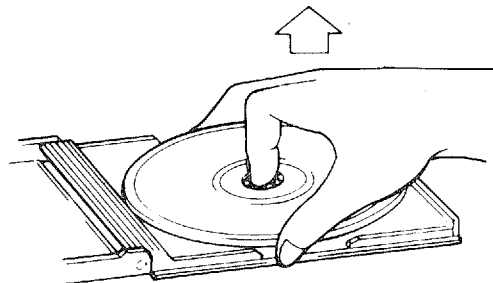

- Always handle the disc with care so that its surface is not scratched.

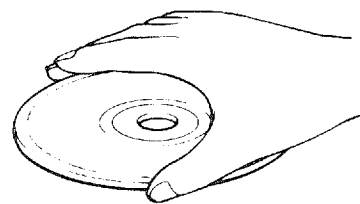

- Compact discs are not subjected to wear during play, but damage to the disc surface when the disc is being handled can adversely affect the disc's play.

- Compact discs are not affected by small particles of dust or fingerprints on their playing surface, but even so they should be kept clean. Wipe by using a clean, dry cloth. Do not wipe with a circular motion; wipe straight outward from the center.

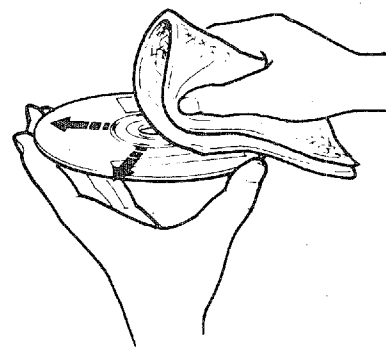

- Do not try to clean the disc's surface by using any type of disc cleaner, record spray, anti-static spray or liquid, or any other, chemical-based liquid, because such substances might irreparably damage the disc's surface.
- Do not expose discs to direct sunlight, high temperature or high humidity for a long period of time, because these might warp or otherwise damage the disc.

**NO!**



## CONTROLS AND THEIR FUNCTIONS

(See Fig. 1.)

### ① POWER switch (POWER)

Press this switch once to switch ON the power; press it again to switch OFF the power.

### ② Disc tray

When the OPEN/CLOSE button is pressed, this tray will open. Place the disc carefully in the round recessed part of the tray. Be sure the disc's label faces upward.

The disc tray can be closed by again pressing the OPEN/CLOSE button, or by gently pressing the front edge of the disc tray, or by pressing the PLAY button, or by pressing a numeric button.

### ③ Remote-control sensor

Signals from the remote-control transmitter are received here.

### ④ Display panel

The display panel displays all of the data and symbols for operation and programming of the unit.

#### ① Disc-in indicator (DISC)

This indicator illuminates when a disc is loaded.

The indicator flashes continuously when the disc tray is opening, when the disc tray is closing (until the unit is ready for play), and when the disc tray is closed (if there is no disc in the tray).

#### ② Track number display (TRACK)

This display shows the track number selected manually, and during play the track number now being played.

#### ③ Time display (TOTAL/TOTAL REMAIN/SINGLE/SINGLE REMAIN)

The TIME display button can be pressed to select any of the four time displays described below.

- **TOTAL:** This display shows the total play time of all tracks on the disc, or the total time of all programmed tracks if the programmed-play feature is being used.

- **TOTAL REMAIN:** This display shows the total play time of all remaining (unplayed) tracks on the disc, or the total time of all remaining (unplayed) programmed tracks if the programmed-play feature is being used.
- **SINGLE:** This display shows the time that has passed since the beginning of play of the track now playing.
- **SINGLE REMAIN:** This display shows the remaining play time of the track now playing.

#### ④ Program number/Tape length display (P-/C-)

This display indicates the program number and the tape length.

#### ⑤ Index number display (INDEX)

This display shows the index number within the track now being played.

#### ⑥ Tape-programming indicators (A O O B)

This indicator illuminates during the program setting of a tape-programming mode (manual tape-programming mode, automatic tape-programming mode, or random-sequential tape-programming mode), and during programmed play.

The "A O O" illuminates during program play (or play stand-by) of side A, and the "O O B" illuminates during program play (or play stand-by) of side B.

#### ★ ⑦ FILE indicator (FILE)

This indicator illuminates during the readout of a filed program pattern, and during the play (or play stand-by) of that pattern. Refer to "PROGRAM FILING".

#### ★ ⑧ SAVE indicator (SAVE)

This indicator illuminates when a program pattern is filed. This indicator remains constantly illuminated while a disc on which a program pattern is filed in the memory is loaded.

#### ⑨ AUTO SPACE indicator (AUTO SPACE)

This indicator illuminates when the automatic-spacing function, which provides a non-recorded interval between tunes is activated.



**⑩ Repeat indicators (SINGLE REPEAT/FULL REPEAT)**

These indicators show which, if any, repeat play mode has been selected. There are two variations of the repeat mode: single repeat and full repeat (explained elsewhere).

- **SINGLE REPEAT:** Indicates the single-repeat mode.
- **FULL REPEAT:** Indicates the full-repeat mode.

**⑪ DELETE indicator (DELETE)**

This indicator illuminates when the DELETE button is pressed, indicating that the unit is in the delete programmed-play mode.

**⑫ PROGRAM indicator (PROGRAM)**

This indicator illuminates when the PROG button is pressed (indicating that the unit is in the programmed-play mode), and illuminates during all tape-programming play modes.

**⑬ RANDOM PLAY indicator (RANDOM PLAY)**

This indicator illuminates when the RANDOM button is pressed, indicating that the unit is in the random-sequential-programmed-play mode.

**⑭ Track calendar (1 - 20)**

When a disc is loaded, the numbers that correspond to the numbers of the tracks on that disc remain displayed, and the other numbers disappear. (Thus, if the disc has 16 tracks, "1" through "16" remain displayed and "17" through "20" disappear.) After each track is played, its corresponding number also disappears, so the number of remaining tracks (and their numbers) can be seen at a glance.

**⑤ PROG button (PROG)**

This button is used to select the manual-programming mode, and also to select the manual tape-programming mode (for recording to a tape).

**⑥ TIME display mode-select button (TIME)**

This button can be used to select the desired time display (elapsed play time for the track now playing, or remaining play time for the track now playing, or total disc play time, or total remaining play time on the disc).

**⑦ AUTO SPACE button (SPACE)**

Press this button to insert an interval of about 4 seconds between tunes when playing.

**⑧ DELETE button (DELETE)**

This button is used to select the delete-program mode, and also to select the automatic tape-programming mode (for recording to a tape).

**⑨ PLAY button (PLAY)**



Press this button to begin play.

**⑩ PAUSE button (PAUSE)**

When this button is pressed during play, the TIME display flashes continuously and disc play is stopped temporarily (without returning to the beginning of the disc). To resume play, press this button again, or the PLAY button; play will begin again from where stopped.

**⑪ STOP button (STOP)**

When this button is pressed, the disc stops. When the PLAY button is next pressed, play will resume from the beginning of the disc (during ordinary play) or from the beginning of the first programmed track (during programmed play).

**12 SKIP button (  SKIP  )**

This button can be used to advance forward or backward directly to the next track during the PLAY, STOP or PAUSE mode. The track number changes by one each time the left or right side of button is pressed, or continues to change if the button is pressed and held. (If the  side is pressed once during the PLAY mode, play starts again from the beginning of the same tune now playing.) After this button is released, the unit remains in the same mode as before it was pressed. (Also refer to "DIRECT SKIP" and "SKIP PLAY".)

**★ 13 Phones level volume control (LEVEL)**

This volume control can be used to adjust the level of the sound heard through headphones.

**14 SEARCH button (  SEARCH  )**

This button can be used to advance rapidly forward or backward. The sounds on the disc can be heard (although slightly garbled) if the unit is in the PLAY mode, thus making it convenient to locate a desired position precisely. When pressed during the PAUSE mode, the action is the same but the sounds cannot be heard. After this button is released, the unit remains in the same mode (PLAY or PAUSE) as before it was pressed. (Also refer to "MANUAL SEARCH" and "INDEX SEARCH".)

**15 PHONES jack (PHONES)**

Headphones can be connected here for listening privately, without disturbing others.

**16 RANDOM button (RANDOM)**

This button is used to select the random-sequence play mode, and also to select the random-sequential-tape-programming mode (for recording to a tape).

**17 REPEAT mode-select button (REPEAT)**

This button can be used to activate (or cancel) the automatic repeat play function.

There are two settings (changing each time the button is pressed, and shown by the display): SINGLE repeat and FULL repeat.

**18 CLEAR button (CLEAR)**

This button can be used to cancel a programmed mode setting.

**19 TAPE button (TAPE)**

This button can be used to select the tape-programming mode (for random-sequential, manual or automatic tape programming), and makes it possible to then enter (into this unit's memory) the total time (length) of the tape to be used for recording from the disc. (Refer to "TRACK PROGRAMMING".)

**20 Numeric buttons (+10 and 1 - 0)**

These buttons are used when selecting the track number(s), either for ordinary play or for programmed play (including programmed play for recording to tapes). These buttons are also used to input the total available time for recording (on a tape to be used for programmed tape recording from a disc).

For a track higher than "9", first press the "+10" button (once for "10" to "19", twice for "20" and higher, etc.) and then press the appropriate button for the second digit.

**21 OPEN/CLOSE button (OPEN/CLOSE)**

The disc tray can be opened and closed by pressing this button.

**★ 22 FILE button (FILE)**

This button can be used when entering a program pattern into the memory's file and when retrieving a program entered into the memory's file.

## REMOTE-CONTROL TRANSMITTER

(See Fig. 1.)

The control functions on the main unit and on the remote-control transmitter are virtually identical, with the exceptions described below. (Refer to "CONTROLS AND THEIR FUNCTIONS" for details of those controls not described below.)

### ⑥ DISPLAY buttons (TIME/MODE)

- ★ ● **TIME:** This button is also on the main unit, and has the same function as that button.
- **MODE:** When this button is pressed one time, the time display changes to the index display; when it is pressed once again, all displays except the time display and the track number display are erased from view. When the button is then pressed once again, the original display returns to view.

### ⑧ INDEX button (INDEX)

When this button is pressed, an index number can be designated for index search.

Some (but not all) discs include these index numbers. These numbers are used on such discs to subdivide tracks into smaller divisions (such as, for example, the movements within classical symphonies) for easier location of those parts. The liner notes with the disc usually tell if such index numbers are included.

### ■ Battery installation

- ① Slide out the battery compartment cover in the direction of the arrow and remove it.
- ② Place two batteries (size "AAA", R03) in the battery compartment. Be sure the batteries are placed to face in opposite directions (as shown in the battery compartment) so that the polarities are correct.
- ③ Replace the battery compartment cover and slide it in until it clicks.

CDX-730

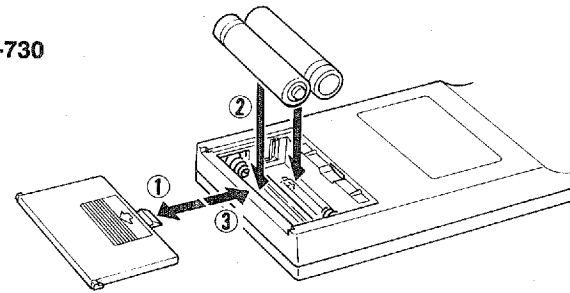

CDX-530

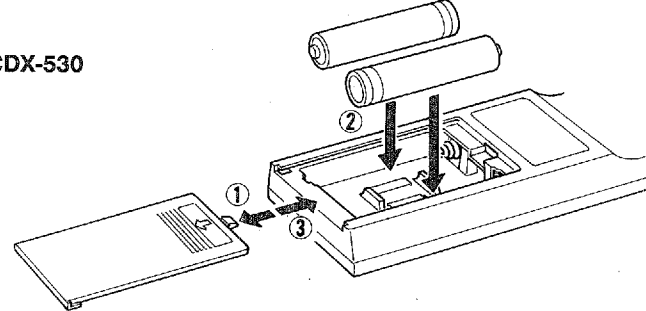

### ■ Remote-control transmitter operation range

Note that the remote-control transmitter should be faced more or less directly toward the main unit when used, and that it should be used within a distance of about seven meters (23 feet); there should be no large obstacles between the remote-control transmitter and the main unit.

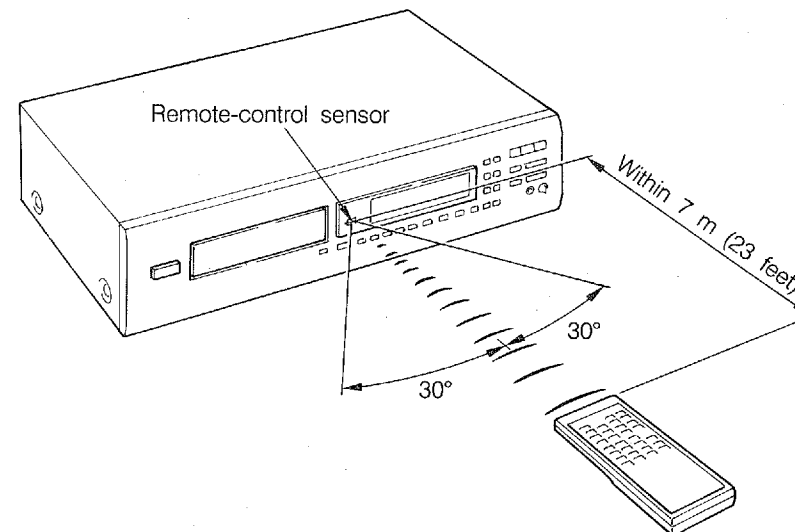

## CONNECTIONS

(See Fig. 2.)

### ■ Battery replacement

If the remote-control transmitter must be used closer to the main unit, the batteries are weak. Replace both batteries with new ones.

#### Notes:

- Batteries may leak, and damage the remote-control transmitter, if handled incorrectly.
- Use only "AAA" (R03) batteries for replacement.
- Be sure the polarities are correct. (See the illustration inside the battery compartment.)
- Do not mix old and new batteries.
- Do not use different types (alkaline, heavy-duty, manganese, nickel cadmium) of batteries at the same time.
- Remove the batteries if the remote-control transmitter will not be used for an extended period of time.
- Replace batteries at the first indication they are weak.
- Never try to open a battery or heat it or throw it into a fire.
- Never connect the battery terminals by using any type of metal wire, etc.
- Two types of batteries (rechargeable and non-rechargeable) are commercially available. Be sure to read the caution label on batteries before using them.
- If batteries leak, immediately dispose of them. Avoid touching the leaked material or letting it come in contact with clothing, etc. Clean the battery compartment thoroughly before installing new batteries.

- Before making any connections, switch OFF the power to the unit and the amplifier or other component.
- ★ ● Connect either the LINE OUT analog output terminals, or the DIGITAL OUT terminal, to the amplifier to be used.
- Connections should be made to the correct input terminals of the amplifier or other component. Refer to that component's operation manual for details.
- If the placement of this unit causes noise to other equipment, such as a tuner, use them farther away from each other.

#### When the LINE OUT (analog) terminals of this unit are used

- Be sure that the connection from the left ("L") LINE OUT analog output terminal and from the right ("R") terminal are to the correct corresponding (left and right) terminals of the amplifier or other component.
- Make the connections from these terminals to the "CD" (or "AUX") terminals of the amplifier. If it does not have such terminals, use the "TAPE PB" terminals. For additional details concerning these connections, refer to the operation instructions for the amplifier being used.

#### ★ When the DIGITAL OUT (OPTICAL) terminal of this unit is used

- Make the connection from this terminal to the digital input terminal of an amplifier or D/A (digital-to-analog) converter by using a commercially available optical fiber cable.
- Before using this terminal, remove the terminal's cover by pulling it.
- Be sure to attach the terminal's cover when this terminal is not being used, in order to protect the terminal from entry of dust.
  - \* Use an optical fiber cable that conforms to EIAJ standards. Other cables might not function correctly.

## LOADING THE DISC / DISC PLAY

1. Press the POWER switch to switch ON the power.
2. Press the OPEN/CLOSE button to open the disc tray.
3. Place a compact disc in the round recessed area of the disc tray, with the label facing upward. Be sure the disc is positioned correctly. The 3-inch (8-cm) type of compact disc should be placed in the smaller, inner recessed area of the disc tray.

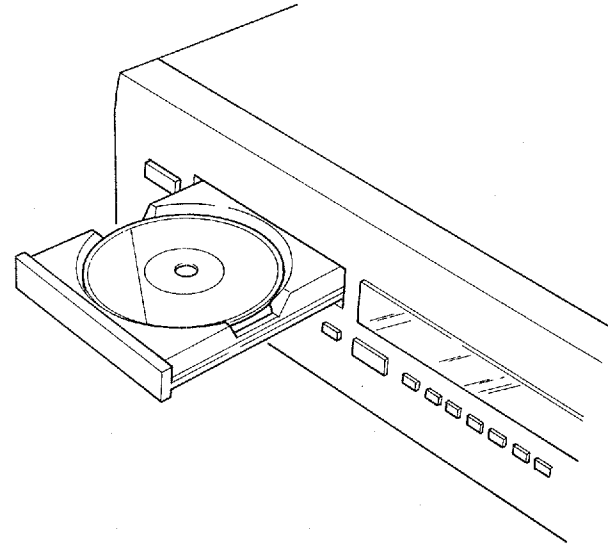

4. Close the disc tray (by pressing the OPEN/CLOSE button, or by pressing the PLAY button, or by pressing the front edge of the disc tray gently, or by pressing a numeric button).
  - \* If the disc tray is closed by pressing the front edge of the disc tray, or by pressing the PLAY button, or by pressing a numeric button, it is not necessary to press the PLAY button again; play will begin automatically.

5. After a few moments during which the unit reads the disc's contents, the TRACK display shows the total number of tracks on the disc, and the TOTAL display shows the disc's total recorded time for a few seconds, if the OPEN/CLOSE button was used to close the disc tray. The unit is then ready for play from track 1 (by pressing the PLAY button).
  - \* If the disc tray was closed by pressing the front edge of the disc tray, or by pressing the PLAY button, the total tracks and total time displays mentioned above will not be shown, and the disc will begin playing automatically from track 1.
  - \* If the disc tray is closed by pressing a numeric button, the corresponding track number will be displayed and the disc will begin playing from the beginning of that track.
6. Press the PAUSE button if it is necessary to stop the play temporarily. To resume play, either press the PAUSE button again or press the PLAY button.
7. To stop play completely (and return to track 1), press the STOP button.
  - Never place anything other than a disc in the disc tray, because to do so could cause a malfunction.
  - Do not use force to open or close the disc tray.
  - Keep the disc tray closed except when loading or unloading a disc.
  - Never press down on the disc tray or place heavy objects on it.

### TRACK CALENDAR DISPLAY

When a disc is loaded, the numbers that correspond to the numbers of the tracks on that disc remain displayed, and the other numbers disappear. (Thus, if the disc has 16 tracks, "1" through "16" remain displayed and "17" through "20" disappear.) After each track is played, its corresponding number also disappears so the number of remaining tracks (and their numbers) can be seen at a glance.

## DIRECT PLAY

To begin play directly from any desired track, simply press the corresponding numeric button(s). Play will begin automatically from the start of that track.

### USING THE NUMERIC BUTTONS

To select track number 10 or higher, press the "+10" button once, and then quickly press the second digit of the track number. (For track "16", therefore, press "+10" + "6".) For track number 20 or higher, the process is the same except that the "+10" button must be pressed two times, etc.

#### Example

To select track 25: 1. Press "+10" twice.  
2. Press "5".

Play will begin automatically from the start of track 25.

- Note that the second button (of a selection that requires two buttons to be pressed) must be pressed soon after the first button is pressed.
- If a track number higher than the highest track number on the disc is selected, the last track on the disc will be played.

## DIRECT SKIP

To begin play from any desired track while in the PAUSE or STOP mode, advance (or return) to that track by pressing the SKIP  $\triangleright\triangleright$  (or  $\triangleleft\triangleleft$ ) button once for each track to be advanced or reversed. Then press the PLAY button to begin play. An alternative method is to use a numeric button(s).

## SKIP PLAY

If the disc is playing, a different track can be selected by pressing the SKIP  $\triangleright\triangleright$  (to advance) or the SKIP  $\triangleleft\triangleleft$  button (to reverse). Press once for each track to be advanced or reversed (except that, for reverse, the first press returns play to the start of the track now playing).

Therefore:

- Press SKIP  $\triangleright\triangleright$  once to advance to the track following the one now playing.
- Press SKIP  $\triangleleft\triangleleft$  once to return to the start of the track now playing.
- Press SKIP  $\triangleleft\triangleleft$  twice to return to the track before the track now playing.

## MANUAL SEARCH

### FAST ADVANCE MANUAL SEARCH

When the SEARCH  $\triangleright\triangleright$  button is pressed during disc play, the play will be rapidly advanced through the music of each track as long as the button is pressed and held. When it is released, play will resume.

### FAST REVERSE MANUAL SEARCH

When the SEARCH  $\triangleleft\triangleleft$  button is pressed during disc play, the play will be rapidly reversed through the music of each track as long as the button is pressed and held. When it is released, play will resume.

#### Manual search notes:

- The search speed will become faster if the SEARCH (  $\triangleleft\triangleleft$  or  $\triangleright\triangleright$  ) button is pressed and held.
- The music can be heard (although slightly garbled) during manual search in either direction. This is convenient for locating a precise position within a track, or for reviewing the contents quickly.
- When manual search in either direction is initiated during the PAUSE mode, the action is the same, but no sound is heard; you can watch the time display to determine where to stop searching.

## INDEX SEARCH

If the disc includes index numbers, play can be started from any desired index number by using a numeric button to designate that index number.

1. First, select the desired track by using the SKIP button (◀◀ or ▶▶) during the PAUSE or STOP mode.
2. Press the INDEX button on the remote-control transmitter. The INDEX number display will begin flashing continuously.
3. Press the numeric button corresponding to the desired index number.
4. Play will then begin from the selected index point.

### Notes:

- Some discs have index numbers, and some do not. The index system is a method for sub-dividing tracks into smaller divisions (such as, for example, the movements within classical symphonies) for easier location of those parts. The liner notes with the disc usually tell if such index numbers are included.
- If an index number is selected that is higher than any index number on that disc, play will start from the last index number point on the disc.
- To cancel the index search function, press the STOP button or INDEX button.
- For some discs, play may begin slightly prior to the actual designated index point.
- If the disc has no encoded index points, play will begin from the start of the track selected by using the SKIP button.
- For some discs, the index search operation may require a slightly longer time than for other discs.
- The index number can be designated only while the INDEX number display is flashing.

## RANDOM-SEQUENCE PLAY

Tracks on the disc can be played in a random sequence selected by the unit's microcomputer. This is useful, especially when combined with full repeat play, to provide background music without a predictable sequence of tunes.

To activate this mode, press the RANDOM button while the unit is in the STOP mode.

The "RANDOM PLAY" indicator will illuminate and the track number display will flash around for a few seconds. Then the track number display will show the track number to be played first, and random-sequence play will begin.

### Notes:

- ★ ● This feature will not function during programming, or during programmed play or file play.
- The total remaining time cannot be displayed during random-sequence play.
- To cancel random-sequence play, press the RANDOM button once again.
- If the STOP button is pressed during random-sequence play, the play will stop and the unit will be in the STOP mode at the beginning of the disc.
- If the SKIP ▶▶ button is pressed during random-sequence play, the next randomly programmed track will be played. If the SKIP ◀◀ button is pressed, play will return to the beginning of the track now being played.

## TRACK PROGRAMMING

### MANUALLY PROGRAMMED PLAY

This feature can be used to program as many as 25 tracks in any desired order.

1. Press the STOP button.
2. Press the PROG button. The TRACK indicator will then begin flashing continuously, the "P-01" indicator will illuminate (if it does not, press the TIME display button), and all track numbers displayed by the track calendar will be erased from view.
3. Press the numeric button corresponding to the track you want to be played first. That number will illuminate in the track calendar; that track number will also be displayed momentarily by the TRACK number display, the total time for all tracks programmed until now will be displayed for a moment, and then the PROGRAM number display will show "02" (meaning the second track-programming selection is to be made next).
4. Make the second selection in the same way as described in 3. above, and so on. As many as 25 tunes can be selected in this way in any desired order.
5. When all selections have been made, press the PLAY button to start programmed play.

- \* The PAUSE mode can also be programmed (one time only), if so desired, by pressing the PAUSE button instead of a numeric button.
- \* Index numbers within tracks cannot be programmed.
- \* The total programmed time will be displayed, but the maximum possible time that can be shown by the display is 99 minutes and 59 seconds. If the total play time exceeds that time, both the total time and total remaining time will not be displayed.
- \* **Information applicable to model CDX-530 only**  
If, for a compact disc with 30 tracks or more, track number 30 or higher is programmed, the total time will disappear from the display.

### SKIP-DELETION OF TRACKS

This feature permits you to delete any programmed selection(s) you don't want to listen to.

1. Press the STOP button.

2. Press the DELETE button. The DELETE indicator and the "P-01" symbol will then illuminate (if it does not, press the TIME display button), and the track numbers that exist on the disc will be displayed by the track calendar.
3. Press the numeric button corresponding to the track to be deleted first. That number will be displayed momentarily by the TRACK number display, and the total time for all tracks programmed until now will be displayed for a moment. In addition, the corresponding track numbers displayed by the track calendar will be deleted from view. Then the PROGRAM number display will show "02" (meaning the second track-deletion selection is to be made next).
4. Press a numeric button for the second track to be deleted, and so on.
5. Press the PLAY button to begin programmed play minus the deleted tracks. Programmed tracks will be played from the lowest numbers of the disc first, skipping those that were deleted.

### Notes for Track Programming

- To check, cancel or correct a programmed setting, refer to "CHECKING, CORRECTING AND CANCELING OF PROGRAMMED SETTINGS".
- When the automatic-spacing function is activated, a four-second non-recorded interval is programmed between each of the programmed tracks.
- If, during program setting, the TIME button is pressed, the program number display can be changed to a display of the total time of the programmed tracks. To return to the previous display, press the TIME button once again.
- The SKIP (◀◀ and ▶▶) button can still be used, but only within the range of the remaining programmed tracks.
- Press the SKIP ▶▶ button to advance to the programmed selection of the number next larger than the one now playing.
- Press the SKIP ◀◀ button to return to the start of the track now playing.
- Press the SKIP ◀◀ button twice to return to the start of the programmed selection prior to the one now playing.
- The SEARCH (◀◀ and ▶▶) button can be used for search throughout all tracks, including unprogrammed tracks.



- If the SEARCH (◀◀ or ▶▶) button is pressed and held beyond the range of a programmed selection(s), the displayed selection will be played and then the unit will continue to the next programmed selection (including unprogrammed tracks).

### MANUAL PROGRAMMING (FOR RECORDING TO TAPE)

This feature is helpful when recording to a tape by using the manual-programming mode, because you can program the tracks so they will fit onto the tape with the least amount of unrecorded space remaining at each end of the tape.

1. Press the STOP button.
2. Press the TAPE button. The "C-" symbol will appear in the display. This indicates that the unit is in the tape-programming mode.
3. Press the appropriate numeric buttons so as to display (after the "C-") the tape's total possible recording time (total time for both sides).  
Example:  
For a C-46 tape (23 minutes on each side, 46 minutes total), display "46" by pressing the "+10" button four times, and the "6" button once. The time will be displayed (C-46).  
\* If any mistake has been made in step 3 (that is, if the incorrect time for the tape is displayed), it should be corrected now, because no correction can be made after the PROG button is pressed in step 4.
4. Press the PROG button to enter the tape's total time in the memory. [The "P-01" symbol will illuminate, and the "TRACK" indicator and the track calendar (only the track numbers on the disc) will begin flashing.] By pressing the TIME button, the TOTAL REMAIN time display will show the amount of time available for programming (on side A).
5. Make the programming settings for the tracks to be recorded (in the same way as for ordinary manual programming).  
\* Each time a selection is made, the track number and the tape's remaining time will be displayed, and then the display will change to indicate the number of the next program.  
\* On the track calendar, the selected tracks will then illuminate, and the indication of those tracks that will not fit into the remaining time will disappear.

#### Notes:

- If the total attempted programming time exceeds the time available for side A of the tape (the side that is to be recorded first), the "E : rr" symbol appears in the display, and that track(s) is not programmed. If the "E : rr" symbol appears, it means that although the attempted track is too long to be programmed, there is on the disc a track that can be programmed for the time remaining on side A of the tape, and that track number is continuously flashed on the track calendar display. To continue programming, press the PAUSE button again to change to the programming of side B of the tape, and then continue programming. At this time, the "O O B" symbol will illuminate on the display.
- If the "E : rr" symbol appears in the TOTAL REMAIN time display, the track for the numeric button just pressed cannot be programmed because there is not enough time remaining on the tape. Either select a shorter track, or use a longer tape.
- If programming is done while the automatic-spacing function is activated, the tape remaining time displayed includes a four-second non-recorded interval between tracks.
- 6. Begin recording on the tape deck and at the same time press the PLAY button on this unit.  
\* When this unit (at the end of side A of the tape) changes to the PAUSE mode, turn the cassette over (to side B). Resume the recording and, at the same time, press the PLAY button or the PAUSE button on this unit.  
\* During recording of the side A of the tape, the "A O O" symbol will illuminate in the display; during recording of the side B, the "O O B" symbol will illuminate.

#### Notes:

- The maximum number of tracks that can be programmed is 25 (P-01 to P-25). If, however, the PAUSE mode is inserted, it is counted as one track.
- **Information applicable to model CDX-530 only**  
This function can be used to program up to and including track number 29. If the disc has more than 29 tracks, track number 30 and thereafter will not be programmed. However, when (and only when) the disc has 30 tracks, track number 30 can also be programmed.

- To check, cancel or correct a programmed setting, refer to "CHECKING, CORRECTING AND CANCELING OF PROGRAMMED SETTINGS".

### **AUTOMATIC PROGRAMMING FOR RECORDING TO TAPE**

This feature can be conveniently used to automatically program the unit to play tracks for recording to tape, without following the manual programming steps, so that the tracks on a disc will be recorded to the tape in sequence, beginning with track 1 of the disc, within the time frame of the tape to be used.

1. Follow steps 1 through 3 of "MANUAL PROGRAMMING (FOR RECORDING TO TAPE)".
2. Press the DELETE button so that the unit will memorize the total recording time available on the tape.

#### **Note:**

Because the display indicates (separately for side A and side B of the tape) the number of programmed tracks, the total time and the sequential number of the programmed selections, it is easy to see the specifics of the programming process at a glance.

3. Begin recording on the tape deck and at the same time press the PLAY button on this unit.
  - \* The display will then show the number of the track now playing, the sequential number of the programmed selections (1, 2, 3 ...), and the elapsed time ("SINGLE" indicator) for the track. This data will change each time a different track is played.
4. When this unit (at the end of side A of the tape) changes to the PAUSE mode, turn the cassette over (to side B). Resume the recording and, at the same time, press the PLAY button or the PAUSE button on this unit.

#### **Notes:**

- Refer to the notes on page 17.
- To check, cancel or correct a programmed setting, refer to "CHECKING, CORRECTING AND CANCELING OF PROGRAMMED SETTINGS".

### **RANDOM SEQUENTIAL PROGRAMMING (FOR RECORDING TO TAPE)**

The CCTP (Computer Controlled Tape Programming) system incorporated within this unit can be used for very easily programming the unit for recording tracks in random sequential order to a tape. By simply providing this unit with the data regarding the time length of the tape (both sides' total), this unit will automatically calculate a random sequential order that will nearly fill both sides of the tape without interrupting a tune before it ends.

1. Follow steps 1 through 3 of "MANUAL PROGRAMMING (FOR RECORDING TO TAPE)".
2. Press the RANDOM button so that the unit will memorize the total recording time available on the tape.
  - \* Because the display indicates (separately for side A and side B of the tape) the number of programmed tracks, the total time and the sequential number of the programmed selections, it is easy to see the specifics of the programming process at a glance.
3. Begin recording on the tape deck and at the same time press the PLAY button on this unit.
  - \* The display will then show the number of the track now playing, the sequential number of the programmed selections (1, 2, 3 ...), and the elapsed time ("SINGLE" indicator) for the track. This data will change each time a different track is played.

#### **Notes:**

- Refer to the notes on page 17.
- Because the programming is done by the unit in random sequence, the programmed data changes, and so therefore does the amount of time remaining at the end of the tape also change accordingly.
- To check, cancel or correct a programmed setting, refer to "CHECKING, CORRECTING AND CANCELING OF PROGRAMMED SETTINGS".

## CHECKING, CORRECTING AND CANCELING OF PROGRAMMED SETTINGS

### To check the programmed settings

1. Press the STOP button.
2. Then press the button corresponding to the settings you want to check:
  - \* Press the PROG button to check the settings for the manual-programming mode, the manual tape-programming mode, the automatic tape-programming mode, or the random-sequential-tape-programming mode.
  - \* Press the DELETE button to check the deleted settings.
3. Each time the SKIP  $\triangleright\triangleright$  button is then pressed, the track numbers and sequential order of the programmed tracks can be checked one after another. The display of the program number can be returned (sequentially in reverse order) to "P-01" by pressing the SKIP  $\triangleleft\triangleleft$  button.

### To correct a programmed setting

1. Follow steps 1 to 3 above.
2. Wherever necessary, press a numeric button to select a track to replace one you want to replace. The previously programmed track will be cleared (from the memory) and the new one will be programmed.
3. After the correction has been completed, once again press the PROG button (or the DELETE button if the mode is the delete-program mode).

#### Note:

If a program number is corrected in all tape-programming modes, the function previously set so as to maintain the recording time according to the tape length will be disabled.

### To cancel a programmed setting

There are several methods, as described below.

- Press the CLEAR button (after programming is completed, or while the unit is in the stop mode).
- Open the disc tray.
- Switch OFF the power.
- The settings for the manual-programming mode are canceled if the DELETE button is pressed after the settings are made but before play begin. The unit is then in the delete-program mode. When the unit is in the delete-program mode, this mode can be canceled by pressing the PROG button; the unit will then be in the manual programming mode.
- The STOP button can be pressed to cancel the random-sequential-programming mode.

## REPEAT PLAY

There are two variations of the repeat-play mode: repeat play of a single track and repeat play of the entire disc.

### SINGLE-TRACK REPEAT PLAY

1. Press the REPEAT mode-select button once. Next (or it can be done prior to this step), use the numeric button(s) to select the number of the track to be repeated. (The "SINGLE REPEAT" indicator will illuminate and the number of the track being repeated will appear.) That track will be played repeatedly until canceled.
2. To cancel the single-track repeat-play mode, press the REPEAT mode-select button twice.

#### Note:

If a SEARCH or SKIP button is used to change to another track, that new track will be played repeatedly until canceled.

### ALL-TRACK ("FULL") REPEAT PLAY

1. Press the REPEAT mode-select button twice. The "FULL REPEAT" indicator will illuminate, and all tracks will be played repeatedly.
2. To cancel the all-track repeat-play mode, press the REPEAT mode-select button once.

#### Notes:

- If the all-track repeat-play mode is selected from the STOP mode, press the PLAY button to begin the repeat play. Play will begin from track 1.
- Repeat play is also possible during the programmed-play mode, the random-sequence play mode.

## ★ PROGRAM FILING

This unit has a function that can be used for storage (filing) of a program pattern that has been set. Only one pattern, a pattern unique for that disc, can be filed for any one disc, and program patterns for a total of as many as about 100 discs can be filed at any one time.

By using this function, there is no necessity to set the program pattern that you prefer (for all discs for which the program pattern has been "filed" in this way) each time those discs are loaded in the unit. Program patterns filed in this way can be retained for about a month, even with the power switched OFF.

### To file a program pattern

1. Set the unit to the STOP mode.
  2. Set a program pattern by following the procedures for manual-track-programming or delete-track-programming. If it has already been set, once again press the PROG button or the DELETE button to change to the program input stand-by mode. (The "TRACK" indicator will begin flashing.)
  3. Press the FILE button. The "SAVE" indicator will then flash for about one second, and then change to steady illumination; the program pattern is now filed in the memory.
- One program pattern can be filed for any one disc. If a different program pattern is filed for a disc, the previous program pattern will be deleted from the file, and only the new program pattern will be retained in the file.
    - \* To make such a change in the program pattern for a disc, follow steps 1, 2 and 3.

## AUTOMATIC SPACING

ENGLISH

### To delete a program pattern

1. Press the STOP button to set the unit to the STOP mode.
  2. If a program pattern is already set, press the CLEAR button to cancel that program pattern.
  3. Press the PROG button. (Do not make a program setting.)
  4. When the FILE button is pressed, the "SAVE" indicator will be erased from view; the program pattern for that disc is now deleted from the memory's file.
- It is possible, if so desired, to delete all program patterns from the memory's file by switching OFF the power, and then (while pressing and holding the CLEAR button and the "0" numeric button) switching ON the power once again.

### To play a programmed pattern

1. Load the disc. The "SAVE" indicator will illuminate.
  2. If the FILE indicator is OFF, press the FILE button to switch it ON. The "PROGRAM" (or "DELETE") indicator will illuminate at the same time.
  3. When the PLAY button is pressed, the program pattern in the memory's file for that disc will be automatically played. (Programmed play can also be initiated by pressing the disc tray in manually to load the disc.)
- If the FILE indicator is already illuminated, the program pattern of play will automatically begin if the program pattern for that disc is in the memory's file.
  - To stop the play of the filed program pattern and change to ordinary play of the disc, press the CLEAR button. By doing so, the disc will be played in the ordinary sequence of tracks, but the program pattern in the memory's file for that disc will not be deleted from the memory. To once again call out the program pattern, follow steps 2 and 3.

When you are recording a disc onto tape, and if the tracks on the disc are recorded with an insufficient time space between them, the tape recorder will not be able to perform blank search operations correctly. In this case, a recorder search mistake can be prevented by using the AUTO SPACE button to insert sufficient spaces between the recorded tunes.

1. Press the AUTO SPACE button before starting to record the disc. "AUTO SPACE" indicator appears on the display.
  2. Press the PLAY button. Playback will then start, and spaces of about 4 seconds each will be maintained between tracks. In the 4 second period between tracks, the display shows "-- --", with the "-" marks switching OFF from left to right in sequence.
- \* When the automatic-spacing function is in effect, the display of the total time and of the total remaining time will include each of the four-second non-recorded intervals placed between each track.
  - \* This function cannot be set or canceled during a programmed operation.

## TIMER PLAY

Timer play is possible by using a commercially available audio timer with this unit.

1. Prepare the amplifier to be used with this unit.
2. Switch ON the power and load the disc.
3. Set the timer to the time at which you want the play to begin.
4. When the set time is reached, disc play will begin from the first track on the disc (or from the first track of the programmed pattern already filed).

### Notes:

- Be sure to set the amplifier to the desired volume level.
- ★ ● If a program pattern is filed and the pattern is ready to be played, the programmed play will begin at the time set on the timer.

## TROUBLESHOOTING

If the unit fails to operate normally, check the following points to determine whether the problem can be corrected by the simple measures suggested. If it cannot, or if the problem is not listed in the SYMPTOM column, disconnect the unit's power cord and contact your dealer or service center for assistance.

SYMPTOM	PROBABLE CAUSE	REMEDY
<b>The player does not switch ON when the POWER switch is pressed.</b>	The power cord is not connected or not completely connected.	Securely connect the power cord.
<b>The disc tray does not close completely.</b>	A foreign object is obstructing the tray.	Carefully check the disc tray and remove the foreign object.
<b>The DISC indicator does not illuminate.</b>	The disc has been loaded upside down.	Load the disc correctly.
	The disc is damaged.	Check the disc carefully; replace it if necessary.
	There is moisture on the laser pickup.	Wait 20 to 30 minutes after switching the unit ON before trying to play a disc.
<b>Play does not begin.</b>	The disc has been loaded upside down.	Reload the disc with the label side up.
	The disc is dirty.	Clean the disc.
<b>Play is delayed, or begins at the wrong place.</b>	The disc may be scratched or damaged.	Check the disc carefully; replace it if necessary.
<b>No sound.</b>	Improper output cable connections.	Connect the cables properly. If the problem persists, the cables may be defective.
	Improper amplifier operation.	Set the amplifier controls to the correct input selection.
<b>Sound "skips".</b>	The player is being subjected to vibrations or impacts.	Relocate the player.
	The disc is dirty.	Clean the disc.
<b>Sound "hums".</b>	Improper cable connections.	Securely connect the audio cables. If the problem persists, the cables may be defective.
<b>Noise from a nearby tuner.</b>	The tuner is too close to the player.	Move the tuner and player farther apart.
<b>Noise from within the disc tray.</b>	The disc may be warped.	Replace the disc.

## SPECIFICATIONS

### AUDIO SECTION

Frequency response	5 Hz – 20 kHz, +0.5/–1.0 dB
De-emphasis equalization	±0.5 dB
Harmonic distortion + noise	Less than 0.005% (1 kHz)
S/N ratio	106 dB
Dynamic range	More than 94 dB
Wow & flutter	Unmeasurable
Channel separation	More than 90 dB (1 kHz)
Output voltage	2V
Output impedance	2.2 k-ohms
Headphones output (–20 dB)	
CDX-730	630 mV/150 ohms
CDX-530	110 mV/150 ohms

### INTERNAL SYSTEM

Optical pick-up	3-beam laser
Error correction system	CIRC
D/A conversion	18-bit linear
Filters	Hi-Bit 8-Fold Oversampling Digital filter 3rd Order New Active Filter

### GENERAL

#### Power requirements

U.S.A. and Canada models	120V, 60 Hz
Australia and U.K. models	240V, 50Hz
Europe model	220V, 50 Hz
General model	110 – 120/220 – 240V, 50/60 Hz

Power consumption ..... 20W

#### Dimensions (W x H x D)

CDX-730	435 x 92.5 x 271 mm (17-1/8" x 3-11/16" x 10-11/16")
CDX-530	435 x 92.5 x 267 mm (17-1/8" x 3-11/16" x 10-1/2")

#### Weight

CDX-730	3.9 kg (8 lbs. 9 oz.)
CDX-530	3.7 kg (8 lbs. 2 oz.)

#### Accessories

.....	Connection cord
.....	Remote control transmitter
.....	Batteries (size "AAA", R03)

Please note that all specifications are subject to change without notice.