

# YAMAHA AX-630

*Natural Sound Active Servo Processing Amplifier*

*85W + 85W (8 $\Omega$ ) RMS Output Power, 0.01% THD, 20-20,000Hz*

*CD DIRECT for High Quality Sound*

*Continuously Variable Loudness Control*

*ALA (Absolute Linear Amplification) Circuit*

*Increased Low Impedance Drive Capability*

*Banana Plug Speaker Terminals for Easy Connection*

CENTER

改訂版

内容

本文中マーキング箇所  
訂正追加を致します。

## CONTENTS

Safety Instructions .....	2
Precautions .....	3
Front Panel .....	4
Connection Diagram .....	5
The Active Servo Technology .....	6
About This Unit .....	6
Front Panel Description .....	7
Connections .....	8
Operations .....	9
Troubleshooting .....	10
Specifications .....	11



## SAFETY INSTRUCTIONS

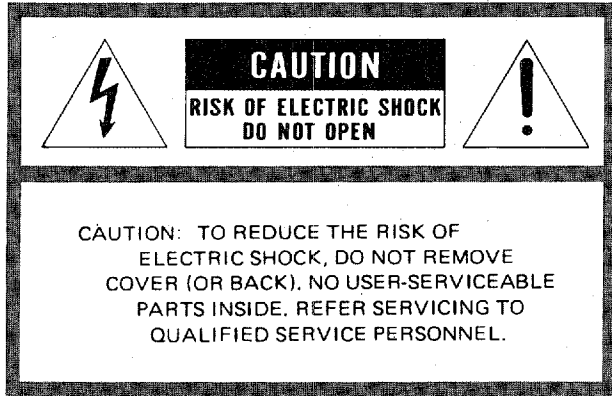

• Explanation of Graphical Symbols

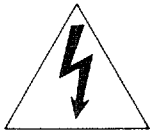

The lightning flash with arrowhead symbol, within an equilateral triangle, is intended to alert you to the presence of uninsulated "dangerous voltage" within the product's enclosure that may be of sufficient magnitude to constitute a risk of electric shock to persons.



The exclamation point within an equilateral triangle is intended to alert you to the presence of important operating and maintenance (servicing) instructions in the literature accompanying the appliance.

### WARNING

To reduce the risk of fire or electric shock, do not expose this appliance to rain or moisture.

**1** Read Instructions – All the safety and operating instructions should be read before the appliance is operated.

**2** Retain Instructions – The safety and operating instructions should be retained for future reference.

**3** Heed Warnings – All warnings on the appliance and in the operating instructions should be adhered to.

**4** Follow Instructions – All operating and other instructions should be followed.

**5** Water and Moisture – The appliance should not be used near water – for example, near a bathtub, washbowl, kitchen sink, laundry tub, in a wet basement, or near a swimming pool, etc.

**6** Carts and Stands – The appliance should be used only with a cart or stand that is recommended by the manufacturer.

**6A** An appliance and cart combination should be moved with care. Quick stops, excessive force, and uneven surfaces may cause the appliance and cart combination to overturn.



**7** Wall or Ceiling Mounting – The appliance should be mounted to a wall or ceiling only as recommended by the manufacturer.

**8** Ventilation – The appliance should be situated so that its location or position does not interfere with its proper ventilation. For example, the appliance should not be situated on a bed, sofa, rug, or similar surface that may block the ventilation openings; or placed in a built-in installation, such as a bookcase or cabinet that may impede the flow of air through the ventilation openings.

**9** Heat – The appliance should be situated away from heat sources such as radiators, stoves, or other appliances that produce heat.

**10** Power Sources – The appliance should be connected to a power supply only of the type described in the operating instructions or as marked on the appliance.

**11** Power-Cord Protection – Power-supply cords should be routed so that they are not likely to be walked on or pinched by items placed upon or against them, paying particular attention to cords at plugs, convenience receptacles, and the point where they exit from the appliance.

**12** Cleaning – The appliance should be cleaned on as recommended by the manufacturer.

**13** Nonuse Periods – The power cord of the appliance should be unplugged from the outlet when left unused for a long period of time.

**14** Object and Liquid Entry – Care should be taken so that objects do not fall into and liquids are not spilled into the inside of the appliance.

**15** Damage Requiring Service – The appliance should be serviced by qualified service personnel when:

- A.** The power-supply cord or the plug has been damaged; or
- B.** Objects have fallen, or liquid has been spilled in the appliance; or
- C.** The appliance has been exposed to rain; or
- D.** The appliance does not appear to operate normally or exhibits a marked change in performance; or
- E.** The appliance has been dropped, or the cabinet damaged.

**16** Servicing – The user should not attempt to service the appliance beyond those means described in the operating instructions. All other servicing should be referred to qualified service personnel.

**17** Power Lines – An outdoor antenna should be located away from power lines.

**18** Grounding or Polarization – The precautions that should be taken so that the grounding or polarization is not defeated.

*Thank you for purchasing the YAMAHA Active Servo Processing Amplifier. In order to ensure proper operation for the best possible performance, please read this manual thoroughly before connecting up your new amplifier and turning it on.*

**IMPORTANT!**

Please record the serial number of your unit in the space below.

Serial No:

**PRECAUTIONS**

**OWNER'S MANUAL**

Keep this manual in a safe place for future reference.

**LOCATION**

Avoid placing your unit in direct sunlight or close to a source of heat. Also avoid locations in which the device is likely to be subjected to excessive dust, cold or moisture.

**VENTILATION**

The openings on the cabinet ensure the ventilation of the amplifier. If these openings are obstructed, the temperature inside the cabinet will rise rapidly and eventually damage the circuits. Therefore, avoid placing objects against these openings and do not install your amplifier in a place such that the flow of air through the ventilation openings could be impeded.

**HANDLING**

● Power cord

When removing the power plug from the wall outlet, always pull directly on the plug. Never yank the cord as this may result in damage to the cord and possibly a short-circuit.

If you do not intend to use this unit for an extended period of time, it is advisable to unplug the power cord.

● Switches and knobs

Avoid applying excessive force to the switches and knobs.

● Relocation

Before moving your amplifier, be sure to unplug the power cord and remove all other connecting cables.

**IN CASE OF TROUBLE**

● Troubleshooting Chart

Consult the Troubleshooting Chart for advice on the common operation errors before concluding that your amplifier is faulty.

● Servicing

Do not open the cabinet or attempt to make repairs by yourself, as this may aggravate the damage and expose you to an electrical shock.

● Object and liquid entry

See to it that foreign objects or spilled liquids do not enter inside the cabinet. Should this case arise, consult your YAMAHA dealer.

**CLEANING**

Wipe off dust with a dry soft cloth. To remove dirt or fingermarks, use a soft damp cloth then dry immediately with a clean cloth. Do not use alcohol, thinners or other chemical solvents since they may damage the finish or remove the panel lettering.

Do not use any aerosol sprays near this unit as these products can easily get into the unit and damage the circuitry.

# FRONT PANEL

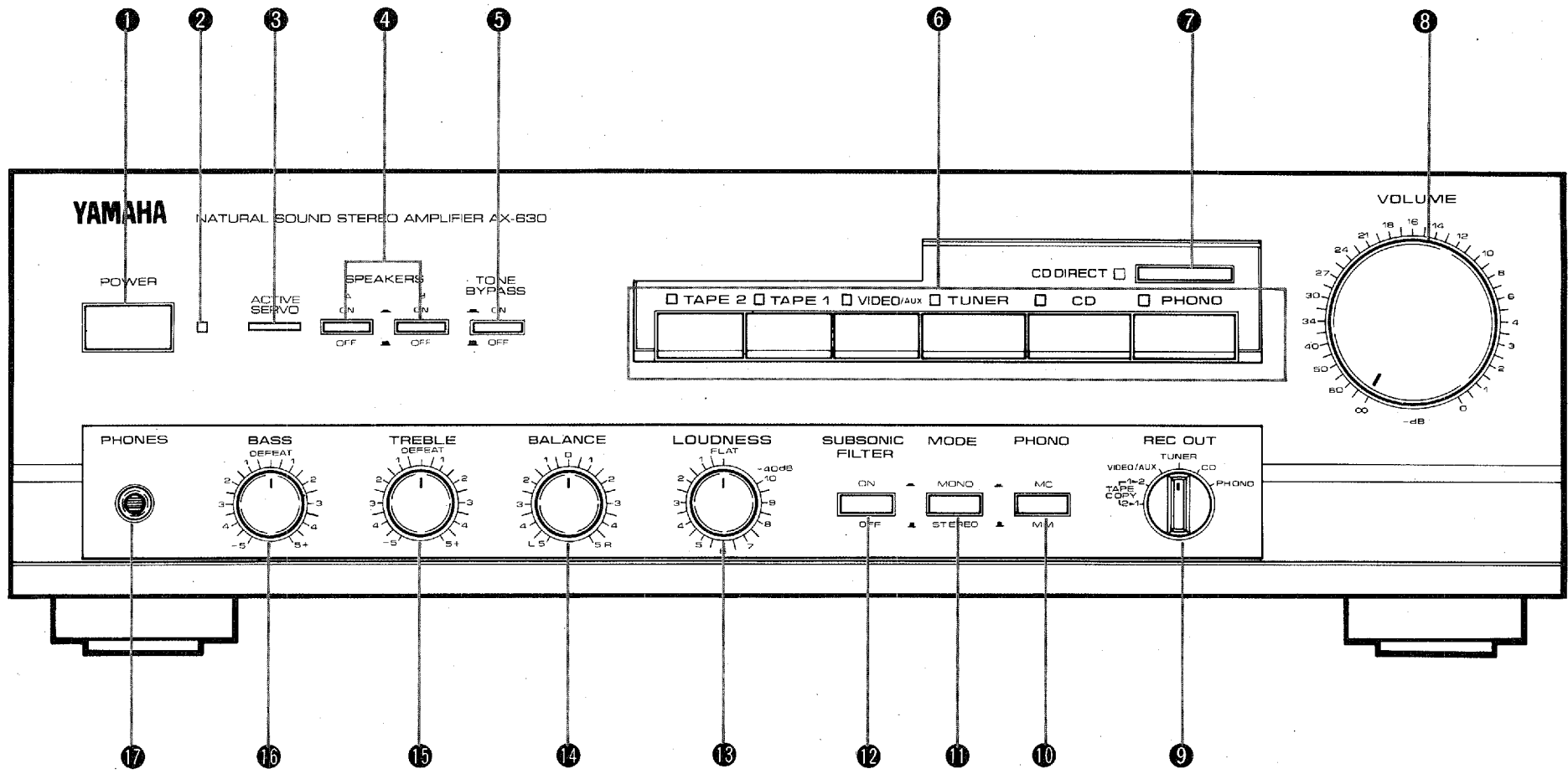

# CONNECTION DIAGRAM

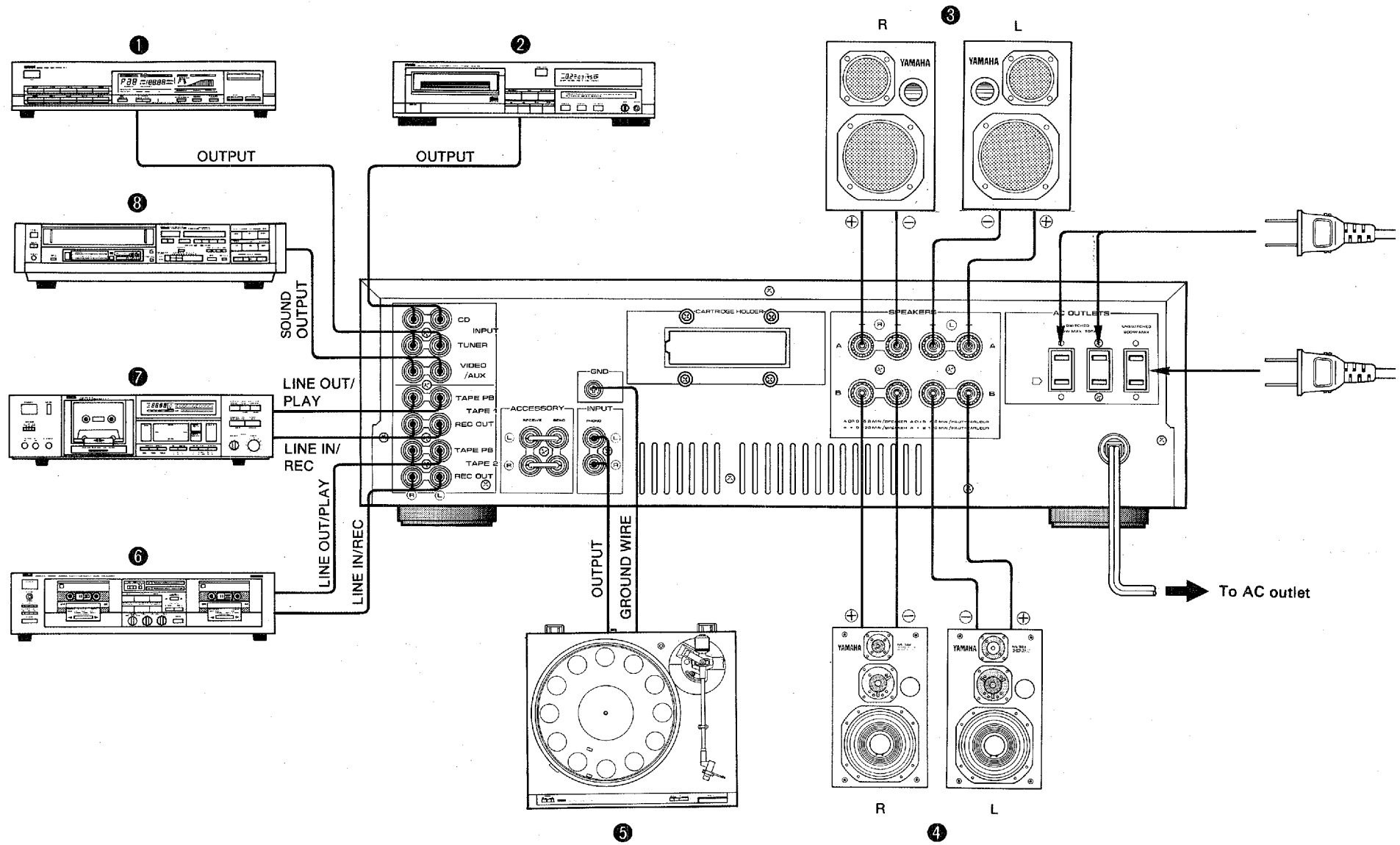

## THE ACTIVE SERVO TECHNOLOGY

The theory of the Active Servo Technology is based upon two major factors, the Helmholtz resonator and negative-impedance drive. Active Servo Processing speakers reproduce the bass frequencies through an "air woofer", which is a small port or opening in the speaker's cabinet. This opening is used instead of, and performs the functions of, a woofer in a conventionally designed speaker system. Thus, signals of low amplitude within the cabinet can, according to the Helmholtz resonance theory, be output from this opening as waves of great amplitude if the design is such that the size of the opening and the volume of the cabinet are in the correct proportion to satisfy a certain ratio. In order to accomplish this, moreover, the amplitudes within the cabinet must be both precise and of sufficient power because these amplitudes must overcome the "load" presented by the air that exists within the cabinet.

Thus it is that this problem is resolved through the employment of a design in which the amplifier functions to supply the signals. If the electrical resistance of the voice coil is reduced to zero, the movement of the speaker unit would become linear with respect to signal voltage, and, to accomplish this, a special negative-impedance output-drive amplifier for subtracting output impedance of the amplifier is used.

By employing negative-impedance drive circuits, the amplifier is able to generate precise, low-amplitude low-frequency waves with superior damping characteristics, and these waves are then radiated from the cabinet opening as high-amplitude signals. The system can, therefore, by employing the negative-impedance output drive amplifier and a speaker cabinet with the Helmholtz resonator, reproduce an extremely wide range of frequencies (28 Hz—20 kHz) with amazing sound quality and less distortion. The features described above, then, are combined to be the fundamental structure of the Active Servo Technology.

## ABOUT THIS UNIT

The function of this unit differs depending on whether the Active Servo Processing cartridge is connected to this unit or not.

- If the cartridge is not connected to this unit, this unit functions only as an ordinary amplifier. In this instance, speaker system "A" (connected to SPEAKERS terminals "A") or "B" (connected to SPEAKERS terminals "B") can be used independently, or both "A" and "B" can be used at the same time.
- If the cartridge is connected to this unit, SPEAKERS terminals "A" are only for Active Servo Processing speakers and "B" only for conventional speakers. In this instance, either speaker system "A" or "B" can be used.

### CONNECT THE CARTRIDGE

Insert the Active Servo Processing cartridge (provided with Active Servo Processing speaker systems) into the cartridge holder.

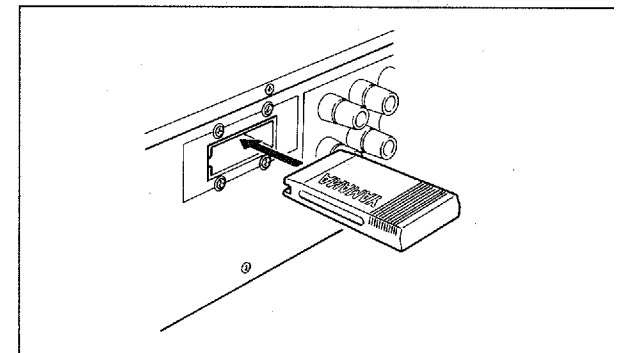

### NOTE

Be absolutely sure that this unit's power is OFF before connecting or disconnecting the Active Servo Processing cartridge to or from this unit.

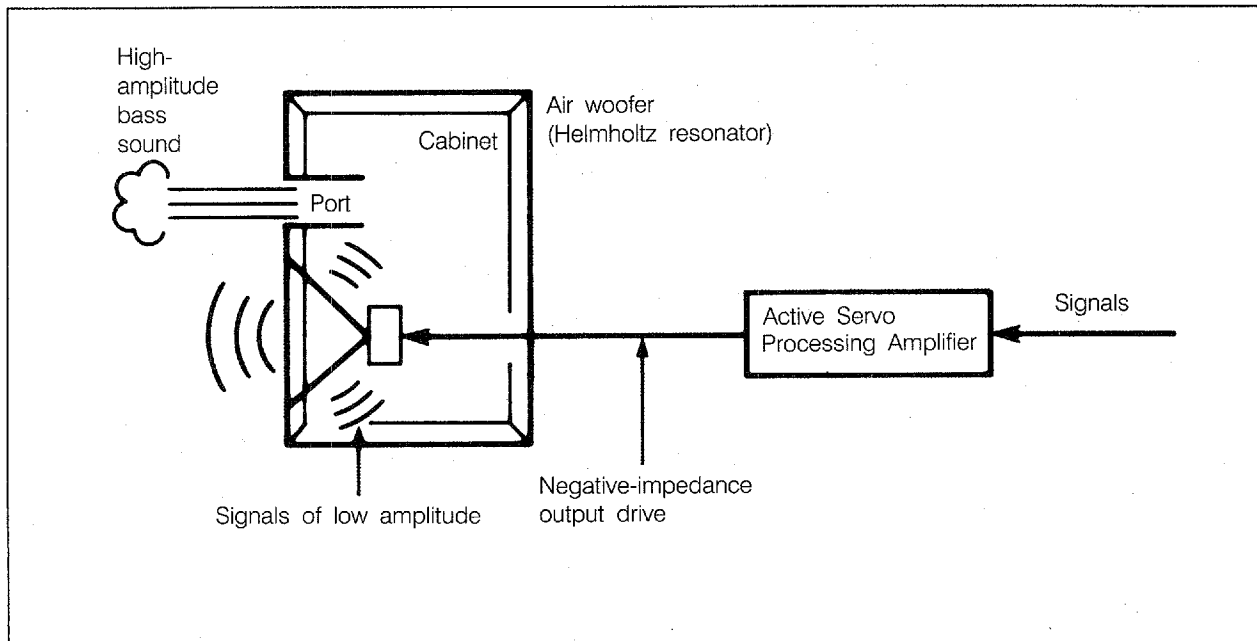

## FRONT PANEL DESCRIPTIONS

The Front Panel illustration is provided on page 4.

### ① POWER SWITCH (POWER)

Press once to turn the power ON and once again to turn the power OFF. Before turning the power ON set the volume to its lowest position (extreme counterclockwise), to protect the speakers from any sudden high level sound.

### ② POWER ON INDICATOR

Illuminated when the power is ON.

### ③ ACTIVE SERVO PROCESSING CARTRIDGE INDICATOR

This indicator illuminates when, with the Active Servo Processing cartridge connected, the SPEAKERS SWITCHES are used to select output from Active Servo Processing speaker systems (connected to the "A" SPEAKERS terminals).

### ④ SPEAKERS SWITCHES (SPEAKERS)

As one or two speaker systems can be connected to this unit, these switches allow you to select speaker system A, B or both at once. If, when the Active Servo Processing cartridge is connected to this unit, both the A and B SPEAKERS switches are switched ON, the output from the A terminals (to which the Active Servo Processing speaker systems are connected) will automatically have priority, and sound will be output from the Active Servo Processing speaker systems only. When listening to the headphones only, press both the A and B switches to the OFF position.

### ⑤ TONE BYPASS CONTROL SWITCH (TONE BYPASS)

Depress this switch to channel the input signal directly to the output stage of your amplifier, bypassing the Bass, and Treble controls therefore avoiding any "muddying" caused by the switch and circuit routing to provide a pure sound.

### ⑥ INPUT SELECTOR PANEL

Selects the program source you wish to listen to. The indicator LED above the selected source will light up.

### ⑦ CD DIRECT SWITCH (CD DIRECT)

This switch allows you to route the CD input signal directly to the output stage bypassing the Input Selectors, the Mode, Loudness, and Balance controls therefore avoiding any "muddying" caused by the switch and circuit routing to provide a pure sound.

### ⑧ VOLUME CONTROL KNOB (VOLUME)

This controls the sound level. Turning clockwise increases the sound volume and turning counterclockwise decreases it. Set this knob to the minimum level before turning the power ON or using the Input Selector Panel to select a different sound source, therefore, protecting the speakers from any sudden high level sound.

### ⑨ REC OUT SELECTOR (REC OUT)

This switch will select a program source and feed that source directly to the rear panel REC OUT terminals independent of the INPUT SELECTORS. This function therefore allows you to listen to any input source while recording another. This control also permits you to record directly from Tape 1 to Tape 2 or vice versa.

### ⑩ PHONO SELECTOR SWITCH (PHONO)

Selects either MM (moving magnet) or MC (moving coil) position to match your cartridge. High performance MC cartridges can be used when in the MM position.

### ⑪ MODE SWITCH (MODE)

Permits switching between stereo and mono operation. Normally this switch should be set to the stereo position.

### ⑫ SUBSONIC FILTER CONTROL SWITCH (SUBSONIC)

This switch cuts out ultra low frequency signals caused by turntable rumble or warped records, yet retains sound quality.

### ⑬ LOUDNESS CONTROL KNOB (LOUDNESS)

This control provides compensation for the human ears loss of sensitivity to high and low frequency ranges at low volumes. As the amount of compensation required is determined by the listening level, this control provides the most accurate compensation for any listening level. Set it to the flat position while the volume control is set to your normal listening level. Turning it counterclockwise will de-

crease the volume while retaining the natural balance of low and high frequencies.

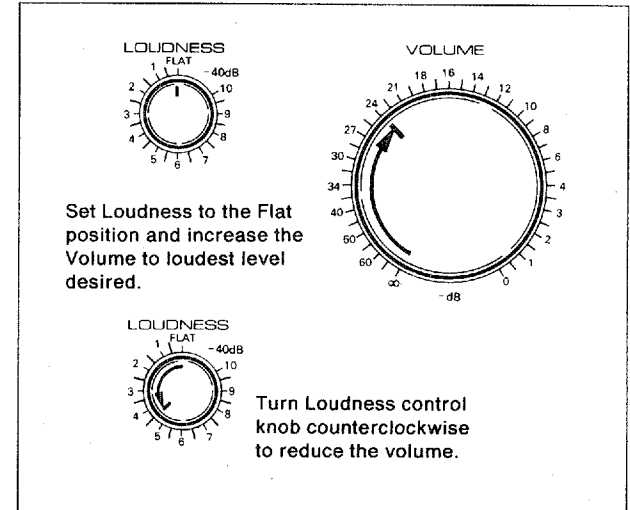

### ⑭ BALANCE CONTROL KNOB (BALANCE)

This knob is used to adjust the relative volume of the left and right channels, enabling you to compensate for unbalance created by installation locations of the speakers.

### ⑮ TREBLE CONTROL KNOB (TREBLE)

This knob controls treble response. Turn it clockwise to boost or counterclockwise to attenuate treble response. When this knob is in the center defeat position, a flat response is obtained.

### ⑯ BASS CONTROL KNOB (BASS)

This knob controls bass response. Turn it clockwise to boost or counterclockwise to attenuate bass response. When this knob is in the center defeat position, a flat response is obtained.

### ⑰ HEADPHONES JACK (PHONES)

Stereo headphones with a standard plug can be connected to this jack. When listening to the headphones only, press both the A and B switches to the OFF position.

## CONNECTIONS

The connection diagram (when the Active Servo Processing cartridge is connected to this unit) is provided on page 5.

- ① Tuner
- ② Compact disc player
- ③ Active Servo Processing Speakers A
- ④ Conventional Speakers B
- ⑤ Turntable
- ⑥ Tape deck 2
- ⑦ Tape deck 1
- ⑧ Video player

*Before making any connections turn off all equipment.*

*Be sure to connect the left (L) and right (R) channels consistently between components.*

### ● CONNECTING THE SPEAKERS

Connect Active Servo Processing speaker systems to the "A" SPEAKERS terminals. If conventional speaker systems are used, connect them to the "B" terminals.

### NOTE

There is the possibility of a malfunction if conventional speaker systems are connected to the "A" terminals with the Active Servo Processing cartridge connected to this unit, and used.

### How to connect speakers cords to the speaker terminals

Connect the cords for the left speakers to the L terminals and the right speaker cords to the R terminals, ensuring that the polarity (+ and -) markings are observed. Be sure to do this consistently from component to component. If the polarity is reversed at either speaker, the sound will be unnatural and lack bass. Speaker cords should be cut as short as possible. Avoid coiling the wire on the floor or bundling it up with cords from other system components.

This unit speaker terminals allow for two connection methods. The first method outlined usually provides the best connection.

1. Strip about 1cm (0,39in) of insulating material from the ends of the speaker wires and twist the strands of each end. Loosen the speaker terminal

knobs, insert the exposed wire into the hole and then tighten the speaker terminal knobs.

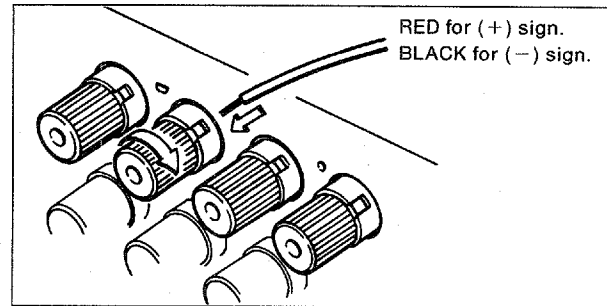

2. Banana Plug connections are also possible. Simply insert the Banana Plug connector into the corresponding terminal.

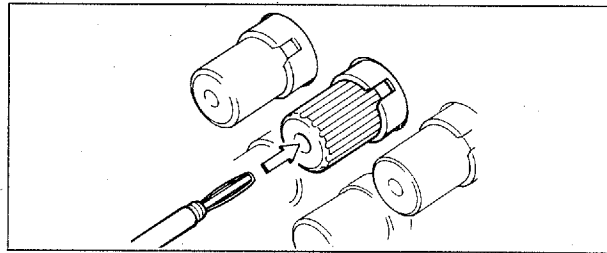

### ● CONNECTING A TURNTABLE

Connect the output cords of the turntable to the Phono jacks and connect the ground wire to the GND terminal. Normally, connecting the ground wire produces minimum hum but in some cases better results are obtained with the ground wire disconnected. The turntable component and its output cords should be positioned well away from sources of hum such as power cords or power transformers of other system components.

### ● CONNECTING A TUNER

Connect the cords from the tuner's output jacks to the TUNER jacks of the amplifier. Position the tuner so that its AM antenna is well away from the amplifier for the best possible reception.

### ● CONNECTING TO THE CD AND VIDEO/AUX JACKS

Connect your CD component to the CD terminals and video sound output leads to the VIDEO/AUX terminals. Please note that a turntable cannot be con-

nected to these jacks as they do not provide the necessary RIAA equalization.

### ● CONNECTING TAPE DECKS

#### TAPE DECK 1.

Connect the cords from the tape deck's Line In jacks to the REC OUT jacks of TAPE 1, ensuring that left and right are not reversed. Then connect the cord from the tape deck's Line Out jacks to the Tape 1 PB jacks.

TAPE DECK 2 can be connected in similar fashion to the Tape 2 terminals.

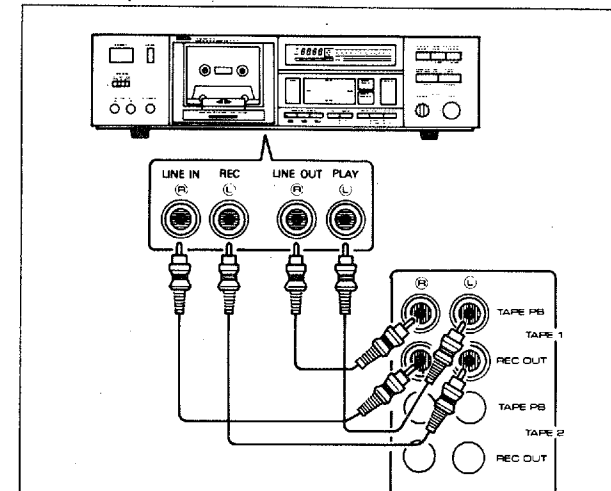

### ● AC OUTLETS

For added convenience this unit provides 3 AC outlets. Two "switched" outlets (the power to these receptacles is turned on and off by this unit's power switch) and one "unswitched" outlet (the power to this receptacle is independent of this unit's power switch). Be sure not to connect appliances totaling more than 200 watts to the unswitched outlet or more than 150 watts to the two switched outlets.

### ● ACCESSORY

The Accessory option allows you to connect a signal processing system, such as an equalizer, in the signal path prior to the Tone control.

Connect the Accessory send jacks to the inputs of the equalizer and the Accessory Receive jacks to the outputs of the equalizer.



## OPERATIONS

### ● Normal listening operation

1. Turn the volume control to the minimum level before turning the power ON. The power indicator is illuminated.
2. Select the desired program source using the Input Selector Panel. The corresponding input indicator lights up.
3. Activate your chosen component.
4. Adjust your VOLUME, LOUDNESS, BASS, TREBLE and BALANCE to provide the desired sound quality.

### ● To record to tape from a sound source





1. Turn the volume control to the minimum setting before turning the power ON. The power indicator is illuminated.
2. Using the REC OUT selector select the source to be recorded.
3. Activate the sound source to be recorded.
4. To monitor the sound being played via the speakers (or headphones) use the Input Selector Panel to select the source program.
5. To start recording activate the receiving tape deck(s). If your tape deck has three head monitoring capability, you can monitor the just recorded signal by selecting the corresponding tape deck switch.
6. To listen to an alternate sound source merely select the desired source using the Input Selector Panel, (noting the procedures outlined above in Normal listening operation). This will have no adverse effect on the recording.

### ● Tape dubbing

As two tape decks can be connected to this unit, tape dubbing can be performed from Tape 1 to 2 or 2 to 1.

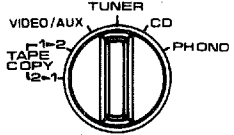
1. Set the REC OUT selector to the Tape Copy position (1 ► 2 or 2 ► 1).
2. To start recording set the source tape deck to playback and the receiving tape deck to record.
3. To monitor the sound being played use the Input Selector Panel to select Tape 1 or Tape 2 according to the source deck. If your tape deck has three head monitoring capability you can monitor the just recorded signal by selecting the corresponding tape deck switch.
4. To listen to an alternate sound source merely select the desired input source using the Input Selector Panel, (noting the procedures outlined above in Normal listening operation) This has no adverse effect on the dubbing quality.

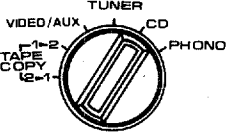
Independent Recording and Listening Examples.

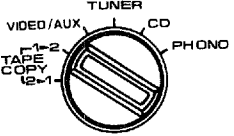
ACTION	INPUT SELECTOR	REC OUT
Listening to a record via the speakers while recording an AM/FM broadcast.	<input type="checkbox"/> PHONO 	
Listening to a CD while recording it.	<input type="checkbox"/> CD 	
Listening to an AM/FM broadcast while "dubbing" a tape from Tape 1 to 2.	<input type="checkbox"/> TUNER 	

## TROUBLESHOOTING

Before assuming that your unit is faulty, please check the following troubleshooting list which details the corrective action you can take yourself without having to call a service engineer. If you have any doubts or questions, contact your nearest Yamaha dealer.

PROBLEM	CAUSE	REMEDY
Power is not supplied even though the Power switch is turned on .	The power plug is not securely plugged in.	Plug it in securely.
There is no sound with any input selector switches pressed.	The Speakers switch is not set correctly.	Set the Speakers switch correctly.
	The input cords are not connected securely.	Connect them securely.
	The speaker system is not connected correctly.	Check and secure connections.
Only CD output is possible	The CD DIRECT switch is ON.	Push the CD DIRECT switch to the OFF position.
There is no sound from one speaker.	The speaker connections are not secure.	Secure the connections.
	The Balance control is set all the way to the left or right.	Adjust the Balance control correctly.
There is a lack of bass and no ambience.	The + and - cords have been reversed at the amp or speakers.	Connect the speaker wires in the correct phase (+ and -).
There is a humming sound when playing records.	The input cords are not connected securely.	Plug the input cords in securely.
	The turntable's ground wire is not connected.	Connect the ground wire.
There is a howling sound when playing records at high volume.	The turntable and the speakers are too close together or the turntable is not mounted on a firm surface.	Change the location of the turntable or the speakers.
Turning the Bass or Treble knob does not affect the tone.	The Tone Bypass switch is on.	The Tone Bypass switch must be turned off to use the controls.
The sound suddenly goes off.	Driving speakers outside the rated impedance range at high power for an extended period has activated the speaker protection circuit.	Turning this unit off and then on will reset the speaker protection circuit. Use speakers inside the rated impedance range.
	There is a malfunction in the amplifier.	Consult your Yamaha dealer.

## SPECIFICATIONS

### Minimum RMS Output Power Per Channel

20Hz~20kHz 0.01% THD 8Ω .....	85W
0.015% THD 6Ω .....	100W

### Dynamic Power Per Channel

#### (by IHF Dynamic Headroom Measuring Method)

8Ω/6Ω/4Ω/2Ω .....	160W/200W/230W/250W
-------------------	---------------------

### Dynamic Headroom

8Ω .....	2.75dB
6Ω .....	3.01dB

### Power Bandwidth

0.03% THD 42.5W 8Ω .....	10Hz~50kHz
--------------------------	------------

### Damping Factor

1kHz 8Ω .....	≥ 100
---------------	-------

### Input Sensitivity/Impedance

Phono MC .....	160μV/220Ω
MM .....	2.5mV/47kΩ
CD/TUNER/VIDEO-AUX/TAPE .....	150mV/47kΩ

### Input Sensitivity (New IHF)

Phono MC .....	19μV
MM .....	0.27mV
CD/VIDEO-AUX/TUNER/TAPE .....	15.5mV

### Maximum Input Signal 1kHz

0.01% THD Phono MC .....	10mV
MM .....	150mV

### Output Level/Impedance

REC OUT .....	150mV/220Ω
---------------	------------

### Headphone Jack Rated Output/Impedance

0.01% THD RL=8Ω .....	0.5V/120Ω
-----------------------	-----------

### Frequency Response

CD/TUNER/VIDEO-AUX/TAPE .....	20Hz~20kHz, ±0.5dB
-------------------------------	--------------------

### RIAA Equalization Deviation

Phono MC .....	±0.5dB
MM .....	20Hz~20kHz, ±0.3dB

### Total Harmonic Distortion 20Hz~20kHz

Phono MC to REC OUT, 3V .....	0.007%
MM to REC OUT, 3V .....	0.003%

### Intermodulation Distortion

CD/TUNER/VIDEO-AUX/TAPE Rated Output/8Ω .....	0.01%
---	-------

### Signal to Noise Ratio (IHF-A-Network)

Phono MC (500μV Input Shorted) .....	76dB
MM (5mV Input Shorted) .....	92dB
CD/TUNER/VIDEO-AUX/TAPE (Shorted) .....	102dB

### Signal to Noise Ratio (New IHF)

Phono MC .....	75dB
MM .....	75dB
CD/VIDEO-AUX/TUNER/TAPE .....	85dB

### Residual Noise (IHF-A-Network)

.....	140μV
-------	-------

### Channel Separation Vol -30dB

Phono MC, MM Input shorted 1kHz/10kHz .....	75dB/60dB
CD/TUNER/VIDEO-AUX/TAPE Input 5.1kΩ .....	75dB/60dB

terminated 1kHz/10kHz

### Tone Control Characteristics

Bass boost/cut .....	± 10dB (20Hz)
turnover frequency .....	350Hz
Treble boost/cut .....	± 10dB (20kHz)
turnover frequency .....	3.5kHz

### Filter Characteristics

Subsonic .....	15Hz - 12dB/oct
----------------	-----------------

### Continuous Loudness Control (Level Related Equalization)

Attenuation .....	- 40dB (1kHz)
-------------------	---------------

### Gain Tracking Error

(0~-60dB) .....	2dB
-----------------	-----

### Power Supply

.....	AC 120V 60Hz
-------	--------------

### Power Consumption

.....	410W
-------	------

### AC Outlets

Switched x 2 .....	80W max.
Unswitched x 1 .....	200W max.

### Dimensions (W x H x D)

.....	435 x 141 x 332mm
-------	-------------------

(17.1 x 5.5 x 13.1 in)

### Weight

.....	8.0kg
-------	-------

(17lbs. 10oz.)

\* Specifications subject to change without notice.

# YAMAHA

---

**YAMAHA ELECTRONICS CORPORATION, USA** 6722 ORANGETHORPE AVE., BUENA PARK, CALIF. 90620, U.S.A.  
**YAMAHA CANADA MUSIC LTD.** 135 MILNER AVE., SCARBOROUGH, ONTARIO M1S 3R1, CANADA  
**YAMAHA ELECTRONIK EUROPA G.m.b.H.** 2084 RELLINGEN, BEI HAMBURG, SIEMENSSTR. 22/34, F.R. OF GERMANY  
**YAMAHA ELECTRONIQUE FRANCE S.A.** 17 RUE DES CAMPANULES, LOGNES 77321 MARNE LA VALLEE CEDEX 2, FRANCE  
**YAMAHA ELECTRONICS (UK) LTD.** YAMAHA HOUSE, 200 RICKMANSWORTH ROAD WATFORD, HERTS WD1 7JS, ENGLAND  
**YAMAHA SCANDINAVIA A.B.** J A WETTERGRENS GATA 1, BOX 30053, 400 43 VÄSTRA FRÖLUNDA, SWEDEN  
**YAMAHA MUSIC AUSTRALIA PTY, LTD.** 17-33 MARKET ST., SOUTH MELBOURNE, 3205 VIC., AUSTRALIA

**YAMAHA CORPORATION**  
10-1 NAKAZAWA-CHO, HAMAMATSU, JAPAN  
VI61210-0 Printed in Japan BWgW, g©